



# **Lecture 2: Surrogate Safety Measures**



# Introduction

- **Crash data** are traditionally used to measure road safety
  - Crash frequency and severity are **direct measures of road safety**.
  - Many types of studies are possible:
    - Black spot analysis
    - Risk models
    - Benchmarking analysis
    - Before-after studies
    - ...

# Introduction

- However, crashes are only the top of the pyramid.

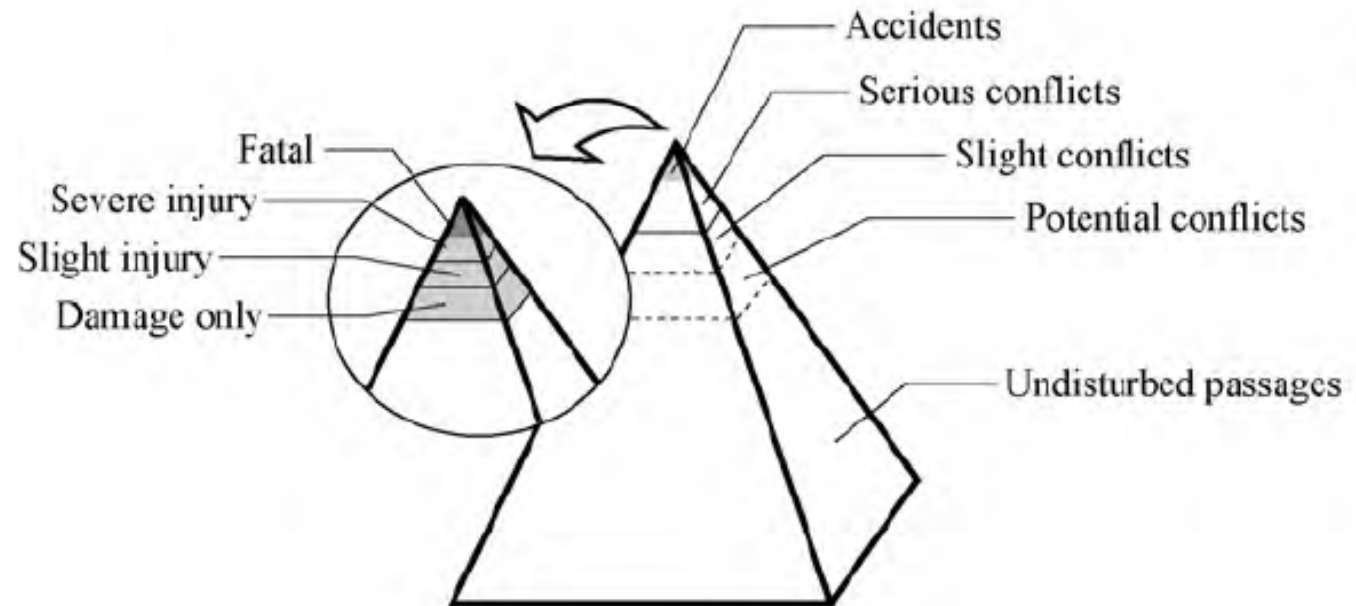



# Introduction

- **Limitations of crash data**

- Rare events

- Small sample sizes may lead to inconclusive results

- Underreporting

- Not all crashes are reported and not all reported crashes are recorded correctly

- Vulnerable to random variation

- Regression-to-the-mean bias

- Lack of details on behavioural and situational aspects of the events

- “Worst case scenario”

- Reactive approach

- Large number of crashes needed before evaluation can take place

# Introduction

- Need for surrogate or complementary safety measures





# Surrogate Safety Measures

- Also known as **indirect safety measures**. They provide a surrogate methodology:
  - when crash frequencies are not available, e.g., the roadway or facility is not yet in service or has only been in service for a short time,
  - when crash frequencies are low or have not been collected,
  - when a roadway or facility has significant unique features.



# Surrogate Safety Measures

- Can be any measure that is not crashes, but are related to them.
  - Should be based on an observable non-crash event, that is physically related in a predictable and reliable way to crashes.
  - There exists a practical method for converting the non-crash events into a corresponding crash frequency and/or severity.



# Surrogate Safety Measures

- Two basic types:
  - Surrogates based on events which are proximate to and usually precede the crash event.
    - e.g., at an intersection encroachment time, the time during which a turning vehicle infringes on the right-of-way of another vehicle may be used as a surrogate estimate.
  - Surrogates that presume existence of a causal link to expected crash frequency.
    - e.g., proportion of occupants wearing seatbelts may be used as a surrogate for estimation of crash severities.





# Surrogate Safety Measures

- The important added attraction of surrogate safety measures is that they may save having to wait for sufficient crashes to materialize before a problem is recognized and a remedy applied.
- In addition, knowledge of the pattern of events that precedes crashes might provide an indication of appropriate preventative measures.



# Surrogate Safety Measures

- Some widely used surrogate safety measures:
  - **Deceleration Rate (DR):** rate at which through vehicle needs to decelerate to avoid crash.
  - **Stopping Distance (SD):** the distance remaining to the projected location of crash.
  - **Time Gap (TG):** the time between the moment of the rear-end of the first vehicle passing a certain point on a road and the front of the following vehicle arriving at that point.

# Surrogate Safety Measures

- Some widely used surrogate safety measures:
  - **Post-Encroachment Time (PET):** time difference between the first vehicle leaving the course of the second vehicle and the second vehicle reaching the course of the first vehicle.

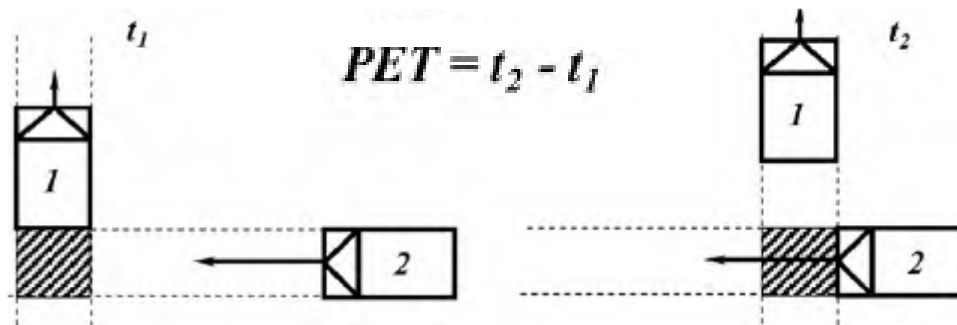

- Speed  $\leq 50$ km/h, serious if PET  $\leq 1$ s
- Speed  $> 50$ km/h, serious if PET  $\leq 1.5$ s

# Surrogate Safety Measures

- Some widely used surrogate safety measures:
  - **Time To Collision (TTC):** the time required for two vehicles to collide if they continue at their present speed and along the same path.

TTC for the case of a right-angle approach

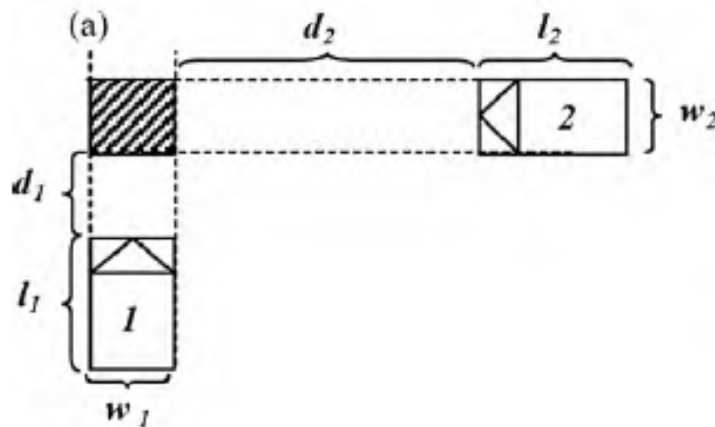

$$\left\{ \begin{array}{l} \text{TTC} = \frac{d_2}{v_2}, \quad \text{if } \frac{d_1}{v_1} < \frac{d_2}{v_2} < \frac{d_1 + l_1 + w_2}{v_1} \\ \text{TTC} = \frac{d_1}{v_1}, \quad \text{if } \frac{d_2}{v_2} < \frac{d_1}{v_1} < \frac{d_2 + l_2 + w_1}{v_2} \end{array} \right.$$

# Surrogate Safety Measures

- Some widely used surrogate safety measures:
  - **Time To Collision (TTC):** the time required for two vehicles to collide if they continue at their present speed and along the same path.

TTC for the case of a rear-end collision

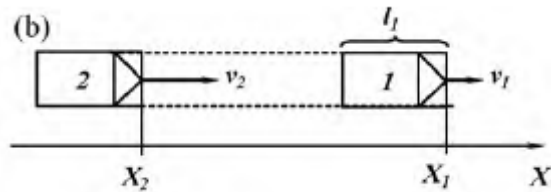

$$\text{TTC} = \frac{X_1 - X_2 - l_1}{v_2 - v_1}, \quad \text{if } v_2 > v_1$$

TTC for the case of a head-on collision

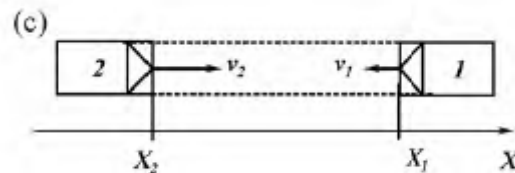

$$\text{TTC} = \frac{X_1 - X_2}{v_1 + v_2}$$



# Surrogate Safety Measures

- Other surrogate safety measures:
  - Time Advantage: predicted PET
  - T2: time for second road user to arrive at the “avoided collision point”
  - Mean speed
  - Speed variance
  - Driver workload
  - Proportion of belted occupants
  - Percentage of drunk driving drivers
  - ...



# Surrogate Safety Measures

- **Strength:**
  - The data for analysis is more readily available.
  - There is no need to wait for crashes to occur.
- **Limitation:**
  - The relationship between the surrogate events and crash estimation is unproven.
- Promising field of research, but still a lot of challenges.



# Traffic Conflict Technique

- What is a traffic conflict?
  - A conflict is an observable situation in which two or more road users approach each other in space and time to such an extent that there is a risk of collision if their movements remain unchanged.
  - A traffic conflict is defined as an event involving two or more road users, in which the action of one user causes the other to make an evasive maneuver to avoid a collision.
  - A traffic conflict is defined as an evasive action taken by a driver in order to avoid a collision.





# Traffic Conflict Technique

- **Identification of traffic conflicts**

- Evasive maneuvers such as applying brakes, swerving, or noticeably decelerating in order to avoid a collision can be considered as conflicts.
  - Brake applications have been usually used as indicators of the occurrence of a conflict.
  - Swerving is also used as an indicator of the occurrence of a conflict, although it sometimes may not be clear.
  - Using perception of deceleration of a vehicle is useful for detecting conflicts when there are no brake light indications.



# Traffic Conflict Technique

- **Analysis of traffic conflicts**

- Conflict type

- right-turn conflict, rear-end conflict, head-on conflict, ...

- Conflict severity

- **Objective method:** rely on physical properties such as time, distance, and speed.

e.g., Time to Collision (TTC) is often used to evaluate conflict severity. TTC is the time required for two vehicles to collide if they continue at their present speed and along the same path.

- **Subjective method:** rely on human observers to record the perceived risk at the moment in which the conflict occurred.

e.g., Risk Of Collision (ROC) is often used to evaluate the severity of conflicts, ROC is based on the severity of the risk perceived while collecting data in the field.

# Traffic Conflict Technique

- **Analysis of traffic conflicts**
  - Conflict severity (cont.)
    - **Severity Score Values**

Severity Score	TTC (seconds)	ROC
1	1.51 – 2.00	Low Risk
2	1.00 – 1.50	Medium Risk
3	0.00 – 0.99	High Risk

# Traffic Conflict Technique

- **Analysis of traffic conflicts**
  - Conflict rate

Rate type	Definition
Conflicts per hour	$CR_1 = \frac{\text{Number of conflicts}}{\text{Number of hours}}$
Conflict per thousand involved vehicles	$CR_2 = \frac{\text{Number of conflicts}}{\sqrt{V_1 \times V_2}} \times 1000$

Note:  $V_1$  and  $V_2$  are interacting traffic volumes

# Traffic Conflict Technique

- **Analysis of traffic conflicts:**
  - Conflict Risk Index

$$RI_j = \sum_{i=1}^n RI_{ij}, \quad RI_{ij} = K_i \times IV_{ij}, \quad K_i = \frac{W_i}{\sum_{i=1}^n W_i}$$

where

$RI_j$  = total conflict risk index of site  $j$

$RI_{ij}$  = risk index of conflict type  $i$  at site  $j$

$K_i$  = relative weight of conflict type  $i$

$IV_{ij}$  = indicator value of conflict type  $i$  at site  $j$  (the indicator value can be a conflict rate, e.g., the number of conflicts per thousand entering vehicles on the site)

$W_i$  = weighting factor of conflict type  $i$  (the severity score values can be used as the weighting factor, e.g., based on a subjective scale that ranged from 1 to 3, in which 1 represents the least severe conflict, and 3 represents the most severe conflict)

$n$  = number of conflict types



# Case study 1

Safety analysis of Right Turn Followed by U-turn (RTUT) as an alternative to Direct Left Turn (DLT), by using traffic conflict analysis

- Basic technical issues

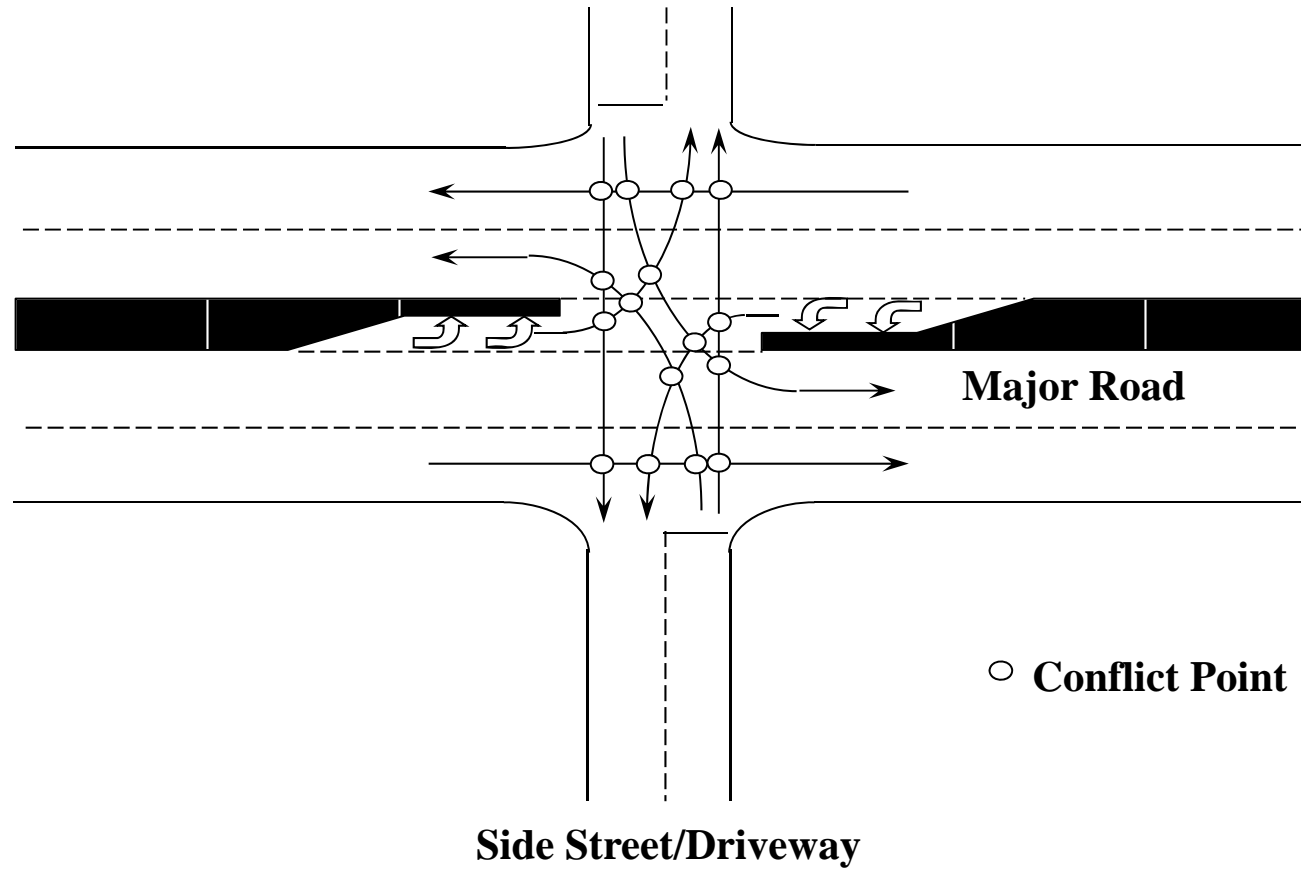

## 16 Major Conflict Points of Direct Left Turns Movements

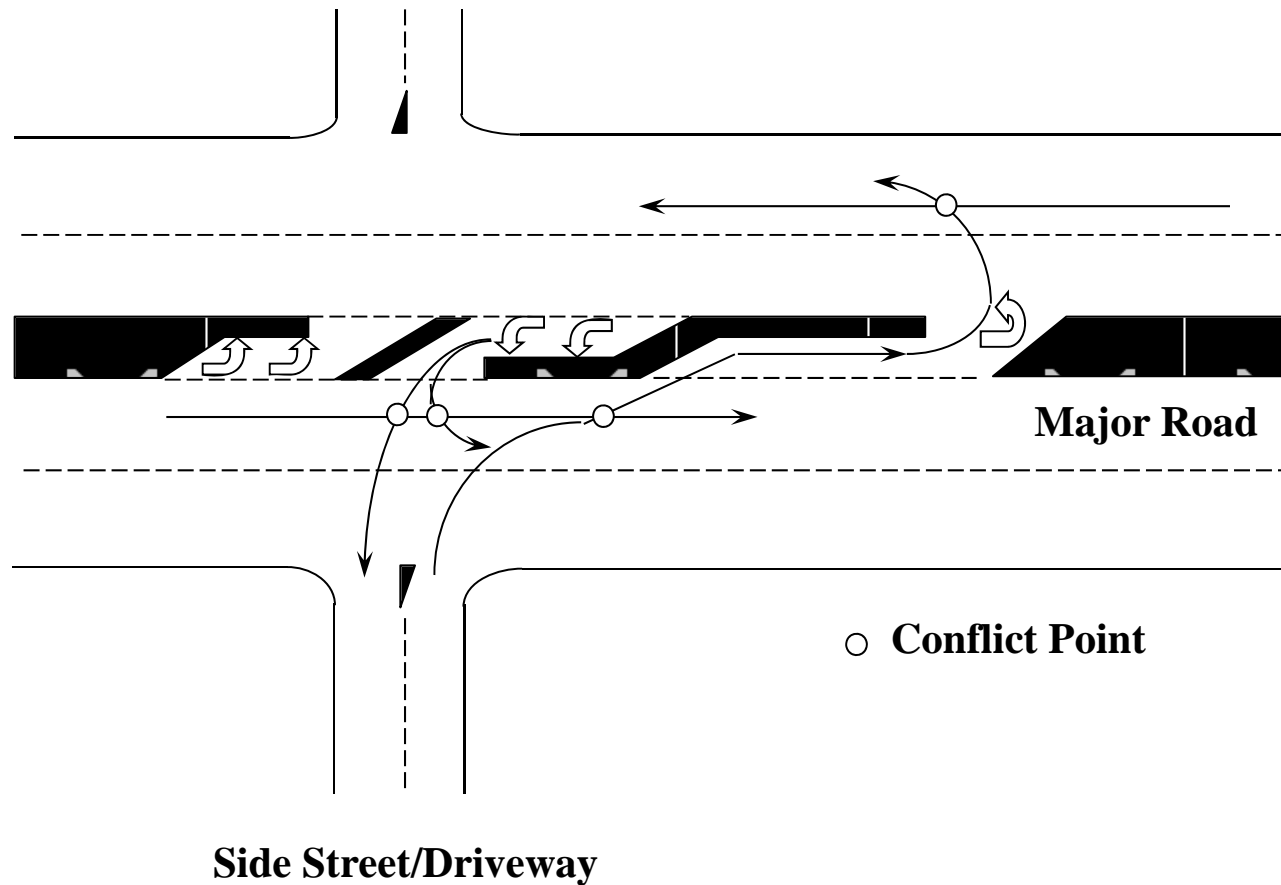

## **4 Major Conflict Points of Right Turn Followed by U-turn Movements**





# Case study 1

Safety analysis of Right Turn Followed by U-turn (RTUT) as an alternative to Direct Left Turn (DLT), by using traffic conflict analysis

- Basic technical issues
  - DLT movements create safety problems.
  - RTUT could be an alternative for improvement.
  - There were no field data to prove the benefit of RTUT.
- Research objective
  - To quantify safety impact of RTUT.



# Case study 1

- Main measure for safety analysis
  - Traffic conflict study was used.
    - Data can be collected in short period of time.
    - Conflicts include human factors.
    - Conflicts provide more information.
- Traffic conflict data collection
  - Video cameras were used to record traffic movements.
  - Good weather, normal traffic conditions, and dry pavement.
  - Video tapes were reduced to obtain traffic movement data and conflict data.

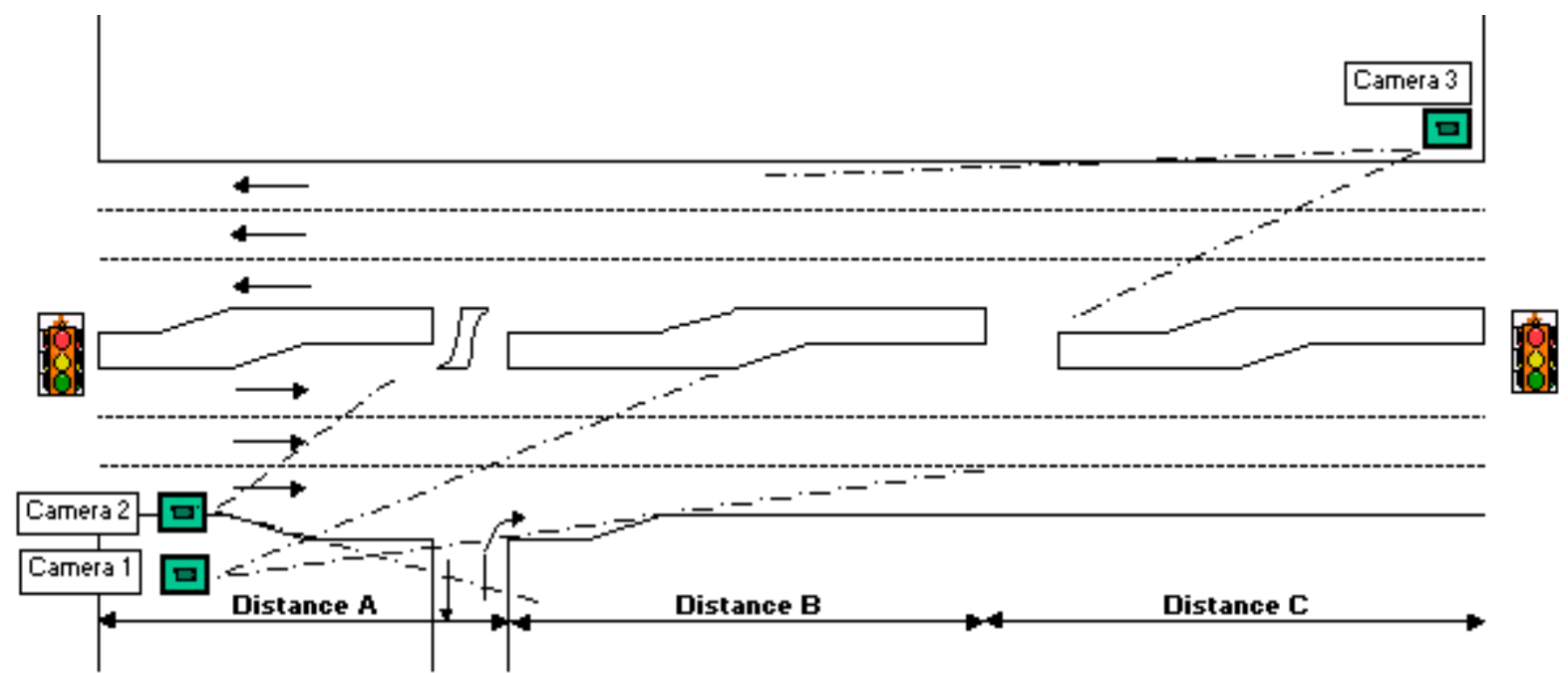
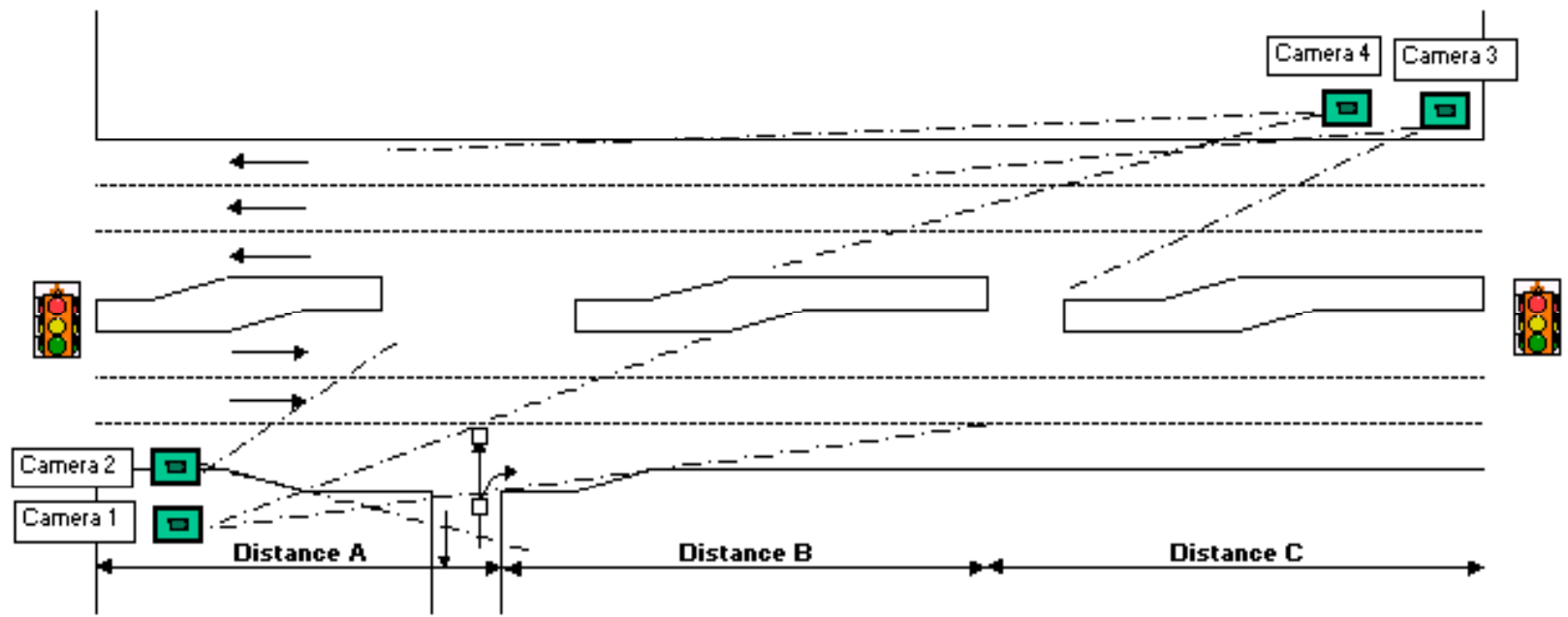













# Case study 1

- 8 sites were selected
  - Arterial with 6 or more lanes
  - Traffic volume on driveway should be relatively high.
  - Effects of upstream and downstream signals should be minimum.

Intersection	Site ID	Number of Lanes		Maneuver allowed		Posted Speed (MPH)	Distances (ft)		
		Arterial	Driveway	DLT	RTUT		A	B	C
Fowler Ave. & 46th St.	1	3	2	No	Yes	45	950	800	700
Fowler Ave. & 19th St.	2	3	4	Yes	Yes	50	700	570	1350
US 19 & 116th Ave.	3	3 & 4	2	Yes	Yes	55	600	420	1620
Bruce B. Downs & Medical Center	4	3	2	Yes	Yes	45	870	970	1160
Hillsborough Ave. & Golden St.	5	3	4	Yes	Yes	45	850	300	750
US 19 & Enterprise Center	6	3	2	Yes	Yes	55	1700	550	4750
US 19 & Innisbrook	7	3	4	Yes	Yes	55	5280	600	5808
Fowler Ave. & 52nd St.	8	3	2	No	Yes	50	1200	580	530

NOTE: Distance A: Distance from driveway to upstream signal.  
 Distance B: Distance from driveway to U-turn bay.  
 Distance C: Distance from U-turn bay to downstream signal.





# Case study 1

- Conflict types studied
  - Type C1. Right turn out of driveway 
  - Type C2. Slow-vehicle same direction 
  - Type C3. Lane change conflict 
  - Type C4. U-turn conflict 
  - Type C5. DLT, conflict from left 
  - Type C6. DLT and left-turn from right 
  - Type C7. DLT and left-turn from left 
  - Type C8. DLT, conflict from right 
  - Type C2U-T. Slow U-turn vehicle, same direction conflict 





# Case study 1

- Conflict data analysis
  - Descriptive analysis 
  - Data analysis
    - Conflict rate: conflicts per hour 
    - Conflict severity 
    - Before-after analysis 

# Case study 2

## Swedish Traffic Conflict Technique

- Elements of a conflict in STCT:
  - Road users involved
  - Speed at the moment of an evasive action
  - Distance to potential point of collision at that moment



# Case study 2

- Time-to-Accident (TA)

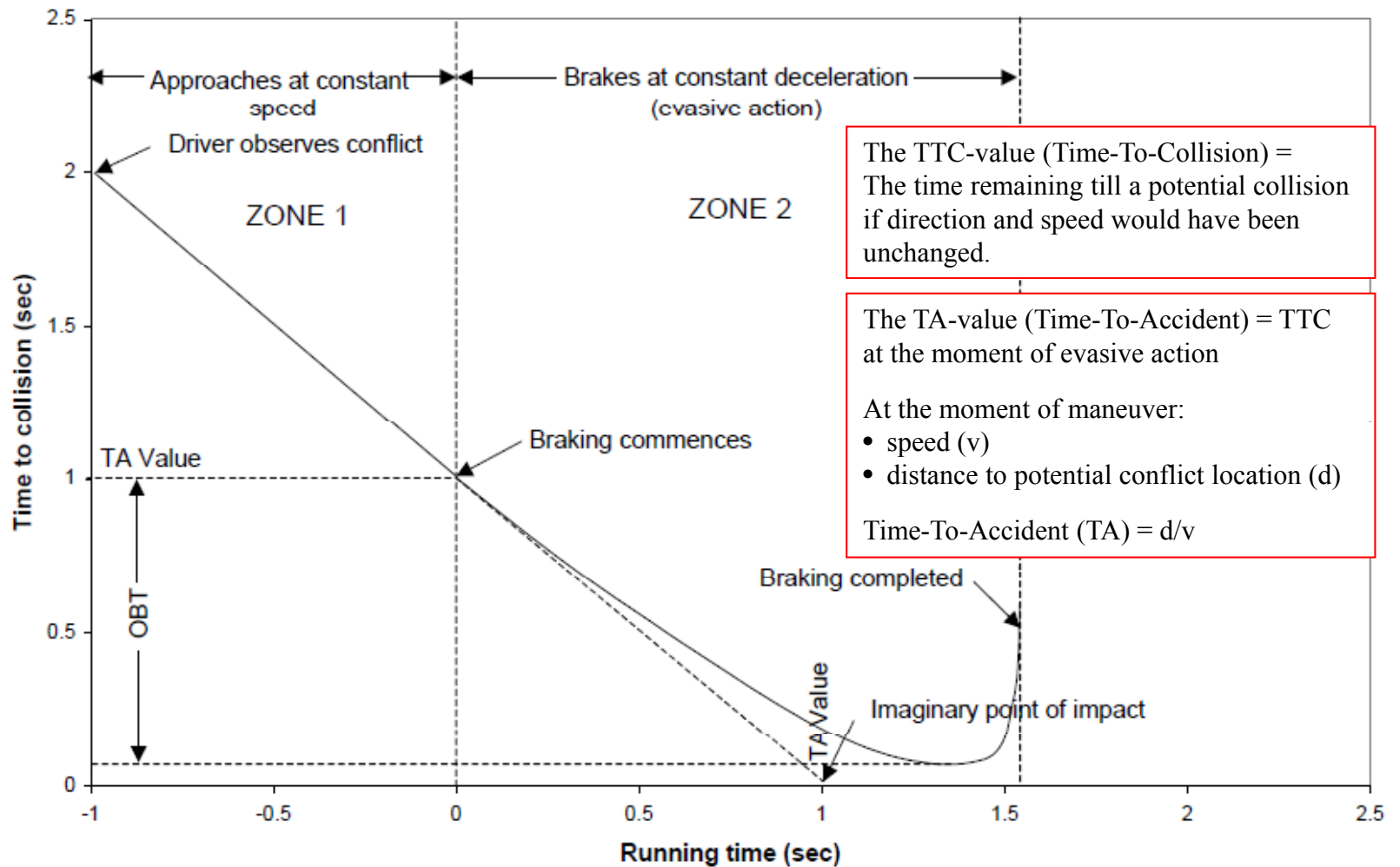

# Case study 2

- Time-to-Accident (TA)

Speed Km/h	m/s	Distance (m)																				
		0,5	10	20	30	40	50	60	70	80	90	100	110	120	130	140	150	160	170	180	190	200
5	1,4	0,4	7,2	14,4	21,6	28,8	36,0	43,2	50,4	57,6	64,8	72,0	79,2	86,4	93,6	100,8	108,0	115,2	122,4	129,6	136,8	144,0
10	2,8	0,2	3,6	7,2	10,8	14,4	18,0	21,6	25,2	28,8	32,4	36,0	39,6	43,2	46,8	50,4	54,0	57,6	61,2	64,8	68,4	72,0
15	4,2	0,1	2,4	4,8	7,2	9,6	12,0	14,4	16,8	19,2	21,6	24,0	26,4	28,8	31,2	33,6	36,0	38,4	40,8	43,2	45,6	48,0
20	5,6	0,1	1,8	3,6	5,4	7,2	9,0	10,8	12,6	14,4	16,2	18,0	19,8	21,6	23,4	25,2	27,0	28,8	30,6	32,4	34,2	36,0
25	6,9	0,1	1,4	2,9	4,3	5,8	7,2	8,6	10,1	11,5	13,0	14,4	15,8	17,3	18,7	20,2	21,6	23,0	24,5	25,9	27,4	28,8
30	8,3	0,1	1,2	2,4	3,6	4,8	6,0	7,2	8,4	9,6	10,8	12,0	13,2	14,4	15,6	16,8	18,0	19,2	20,4	21,6	22,8	24,0
35	9,7	0,1	1,0	2,1	3,1	4,1	5,1	6,2	7,2	8,2	9,3	10,3	11,3	12,3	13,4	14,4	15,4	16,5	17,5	18,5	19,5	20,6
40	11,1	0,0	0,9	1,8	2,7	3,6	4,5	5,4	6,3	7,2	8,1	9,0	9,9	10,8	11,7	12,6	13,5	14,4	15,3	16,2	17,1	18,0
45	12,5		0,8	1,6	2,4	3,2	4,0	4,8	5,6	6,4	7,2	8,0	8,8	9,6	10,4	11,2	12,0	12,8	13,6	14,4	15,2	16,0
50	13,9		0,7	1,4	2,2	2,9	3,6	4,3	5,0	5,8	6,5	7,2	7,9	8,6	9,4	10,1	10,8	11,5	12,2	13,0	13,7	14,4
55	15,3		0,7	1,3	2,0	2,6	3,3	3,9	4,6	5,2	5,9	6,5	7,2	7,9	8,5	9,2	9,8	10,5	11,1	11,8	12,4	13,1
60	16,7		0,6	1,2	1,8	2,4	3,0	3,6	4,2	4,8	5,4	6,0	6,6	7,2	7,8	8,4	9,0	9,6	10,2	10,8	11,4	12,0
65	18,1		0,6	1,1	1,7	2,2	2,8	3,3	3,9	4,4	5,0	5,5	6,1	6,6	7,2	7,8	8,3	8,9	9,4	10,0	10,5	11,1
70	19,4		0,5	1,0	1,5	2,1	2,6	3,1	3,6	4,1	4,6	5,1	5,7	6,2	6,7	7,2	7,7	8,2	8,7	9,3	9,8	10,3
75	20,8		0,5	1,0	1,4	1,9	2,4	2,9	3,4	3,8	4,3	4,8	5,3	5,8	6,2	6,7	7,2	7,7	8,2	8,6	9,1	9,6
80	22,2		0,5	0,9	1,4	1,8	2,3	2,7	3,2	3,6	4,1	4,5	5,0	5,4	5,9	6,3	6,8	7,2	7,7	8,1	8,6	9,0
85	23,6		0,4	0,8	1,3	1,7	2,1	2,5	3,0	3,4	3,8	4,2	4,7	5,1	5,5	5,9	6,4	6,8	7,2	7,6	8,0	8,5
90	25,0		0,4	0,8	1,2	1,6	2,0	2,4	2,8	3,2	3,6	4,0	4,4	4,8	5,2	5,6	6,0	6,4	6,8	7,2	7,6	8,0
95	26,4		0,4	0,8	1,1	1,5	1,9	2,3	2,7	3,0	3,4	3,8	4,2	4,5	4,9	5,3	5,7	6,1	6,4	6,8	7,2	7,6
100	27,8		0,4	0,7	1,1	1,4	1,8	2,2	2,5	2,9	3,2	3,6	4,0	4,3	4,7	5,0	5,4	5,8	6,1	6,5	6,8	7,2
105	29,2		0,3	0,7	1,0	1,4	1,7	2,1	2,4	2,7	3,1	3,4	3,8	4,1	4,5	4,8	5,1	5,5	5,8	6,2	6,5	6,9
110	30,6		0,3	0,7	1,0	1,3	1,6	2,0	2,3	2,6	2,9	3,3	3,6	3,9	4,3	4,6	4,9	5,2	5,6	5,9	6,2	6,5
115	31,9		0,3	0,6	0,9	1,3	1,6	1,9	2,2	2,5	2,8	3,1	3,4	3,8	4,1	4,4	4,7	5,0	5,3	5,6	5,9	6,3
120	33,3		0,3	0,6	0,9	1,2	1,5	1,8	2,1	2,4	2,7	3,0	3,3	3,6	3,9	4,2	4,5	4,8	5,1	5,4	5,7	6,0

speed km/h	serious conflict between:
30	0 and 10 meter
60	0 and 40 meter
90	0 and 90 meter
120	0 and 170 meter

Speed from 30 to 60 km/h -> distance from 10 to 40m  
= 2 times -> 4 times

Speed from 30 to 120 km/h -> distance from 10 to 170m  
= 4 times -> 17 times

# Case study 2

- Time-to-Accident (TA)

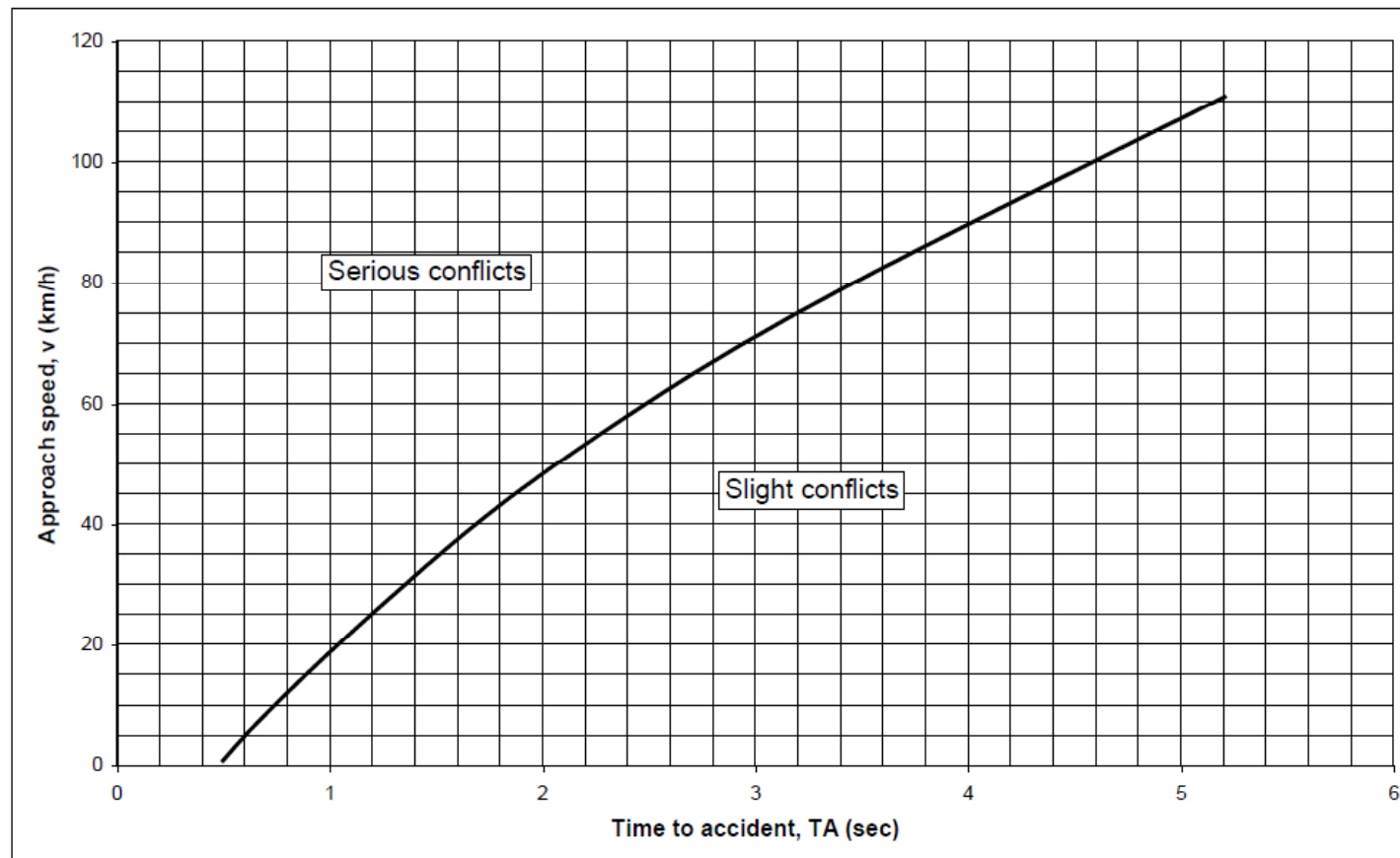

Graph to determine the severity of a conflict (Source: Lund University)



## Case study 2

- In case multiple road users perform an evasive action
  - Determine the Relevant Road User (RRU)
    - Road user with the highest (=least serious) TA value
    - Supposed to control the situation because he/she has the largest margin to take action



# Assignment

## Conducting a traffic conflict study using STCT

- Decide a research objective, as it has impact on:
  - Location: urban or rural, roadway or intersection,...
  - Traffic to be observed: all traffic, specific groups, most vulnerable groups,...
  - When and how long should be observed: peak hours or not, weekday or weekend,...
- Select a location and observation time



# Assignment

## Conducting a traffic conflict study using STCT

- The observers: to be as objective as possible
  - Have a good understanding of what is considered as an “evasive action”
  - Detect situations that can lead to conflicts
  - Estimate the speed of road users involved
  - Estimate the distance to the expected collision point





# Assignment

## Conducting a traffic conflict study using STCT

- At the location: Video cameras
  - To be able to study specific situations in more detail
  - To be able to analyze conflicts occurring simultaneously
  - To check results (e.g., estimate of speed and distance)

# Assignment

## Conducting a traffic conflict study using STCT

- At the location: Camera and observers
  - Weather and light conditions
  - Position of camera(s): be sure what is captured
  - Position of observer(s) and camera(s)
  - Synchronization of time (watches, cellphones, and cameras)

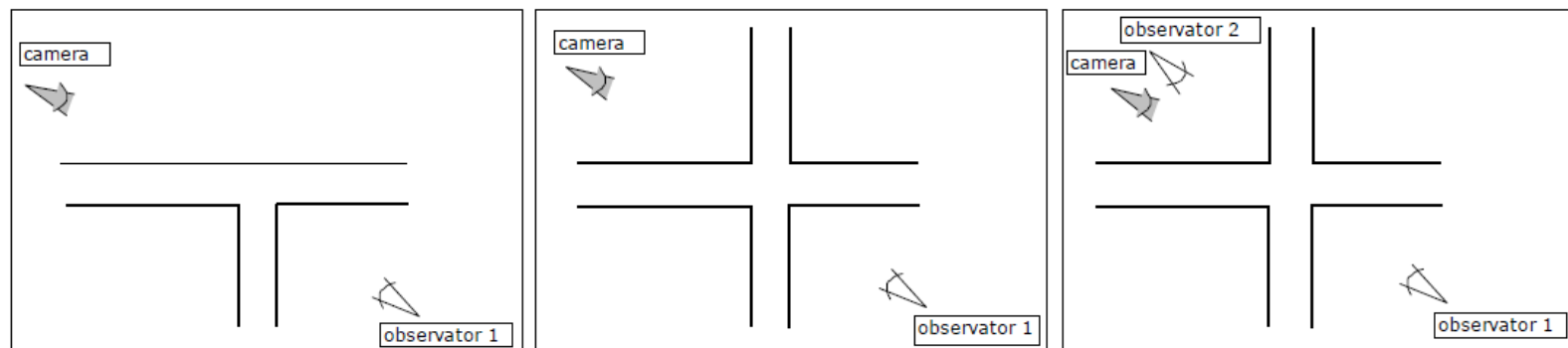



# Assignment

## Conducting a traffic conflict study using STCT

- At the location
  - Distance
    - Thorough exploration of the location by measuring lane width, distances between two lampposts, length of zebra crossing, ...
    - Identify reference points on the spot which can be used to better assess distances during observations.
  - Speed



# Assignment

## Conducting a traffic conflict study using STCT

- Use a conflict observation form
  - List all possible conflicts
  - Note information that helps you to find the conflict back on the video footage
    - Information like time, color of cars, brand of cars, types of road users involved, ...
    - Estimated speed and distance to potential conflict point

# Assignment

## Conducting a traffic conflict study using STCT

- Data analysis
  - Verify all possible conflict with video footage
    - For (potential) serious conflicts: adjust estimations of speed and distances
    - Determine the TA for all road users: take the least serious TA as representative value for the conflict
    - Analysis possibilities:
      - Maneuver diagram of all serious conflicts
      - Identifying dominant conflict types
      - Combinations of road user type, time of occurrence, ...
      - ...

# Assignment

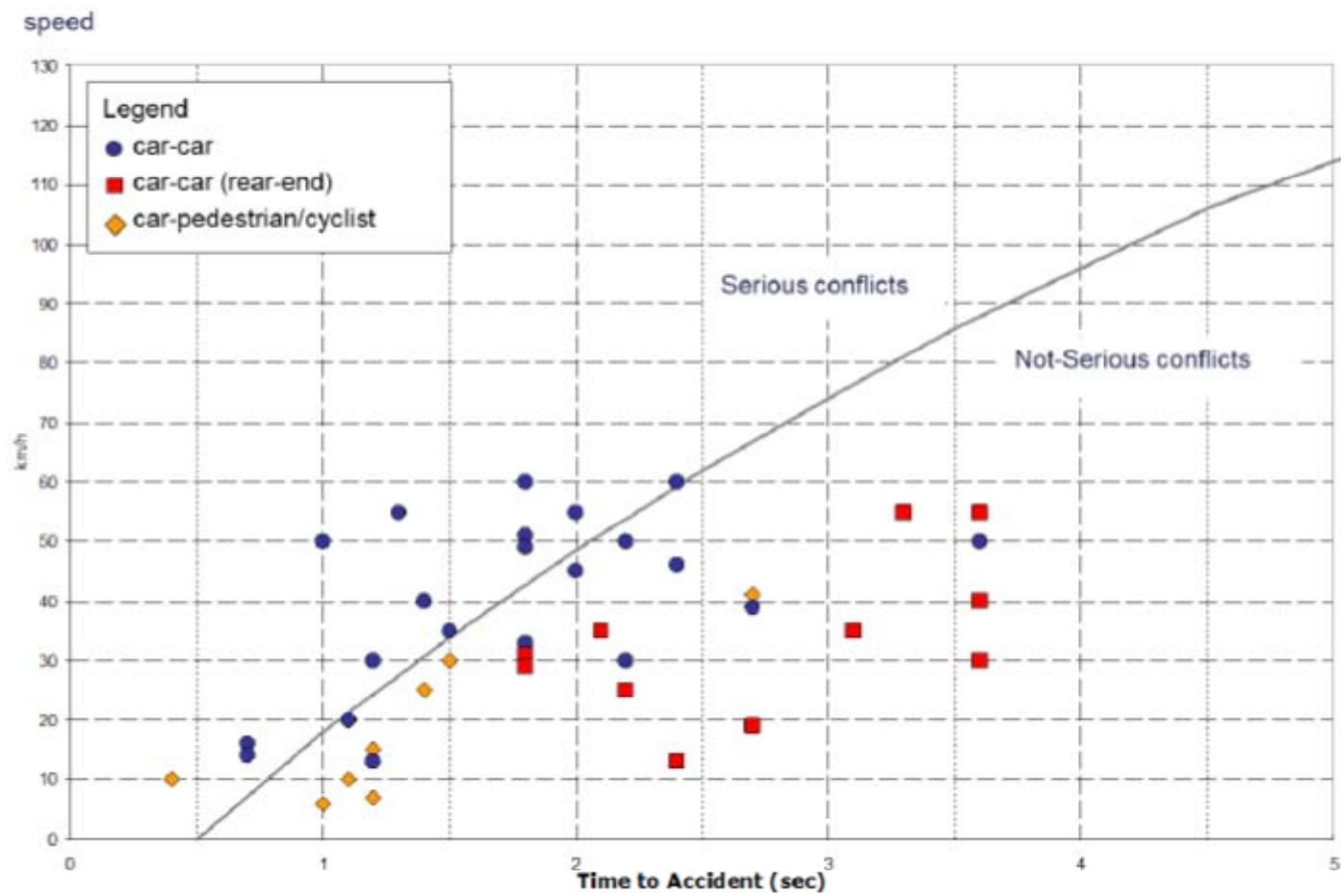



# Summary

- Surrogate safety measures
  - What? Why? How?
- Traffic conflict technique and 2 traffic conflict studies
- Advantages of using traffic conflicts
  - Data can be collected within a short period of time so that an engineer does not have to wait for the occurrence of crashes to improve the conditions of a site.
  - The effectiveness of a treatment can be evaluated within a short period and if this fails to correct the problem then the countermeasure can be changed again in a very short time.



# Summary

- Advantages of using traffic conflicts (cont.)
  - Traffic conflict studies can be used with or without crash data since each type of conflict is associated with a particular type of crash.
  - Traffic conflicts include human factors because the behavior of drivers can directly be observed in the field.
- Disadvantages
  - Only a proxy for crashes. Validity of technique is not fully established yet.
  - Susceptible to adverse weather conditions and difficult at night
  - Labour-intensive data collection





# Summary

- Note: observers are the most important element when conducting a traffic conflict study
  - The reliability of observers has a serious impact on the validity of the data.
  - Training and educating observers are the most important factors considered in the initial stages.
- Future direction
  - Automated Video Analysis
    - Automatically identifying relevant situations from video recordings
    - Automatically measuring conflict indicators based on the calculation of speed, position, time, ...

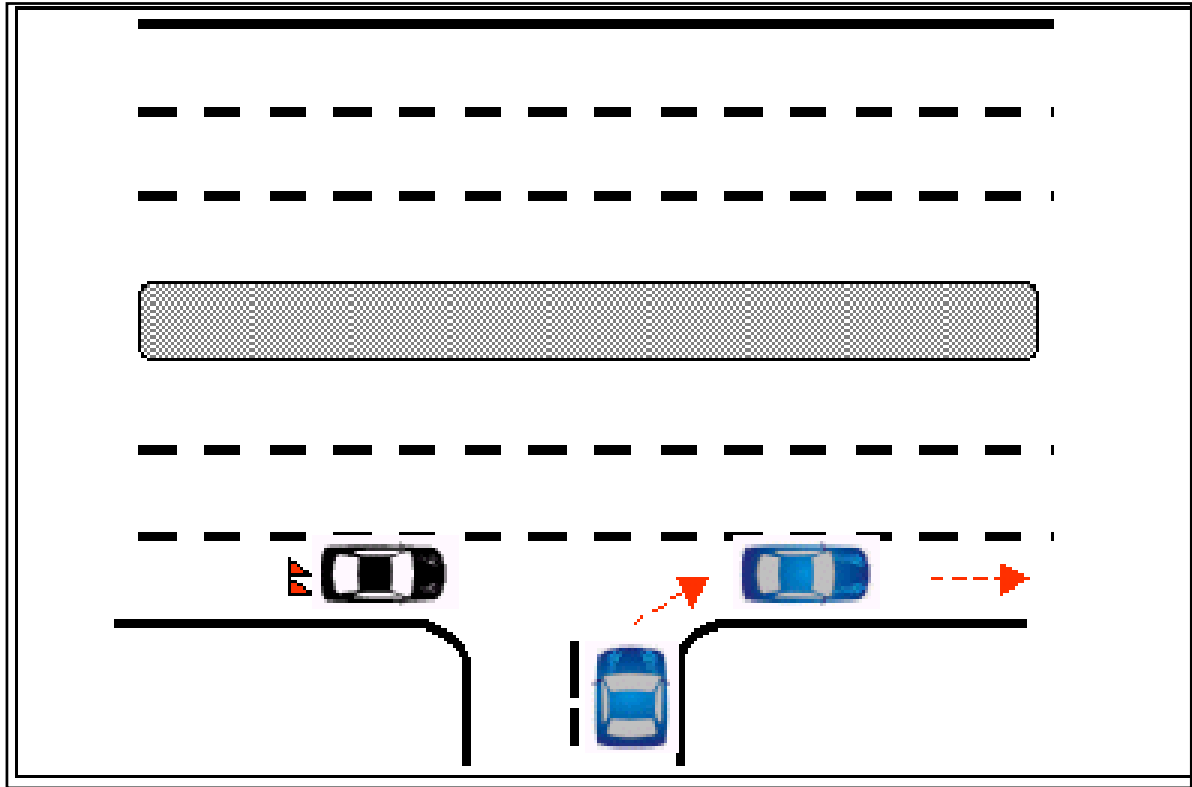

Conflict type C1



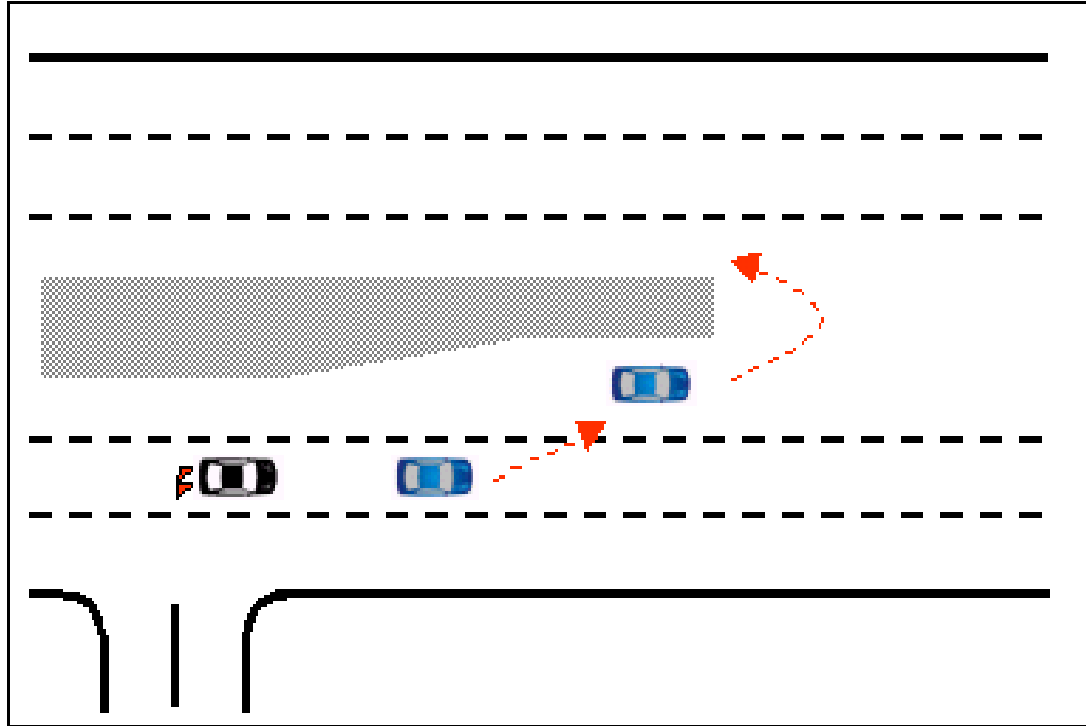

Conflict type C2



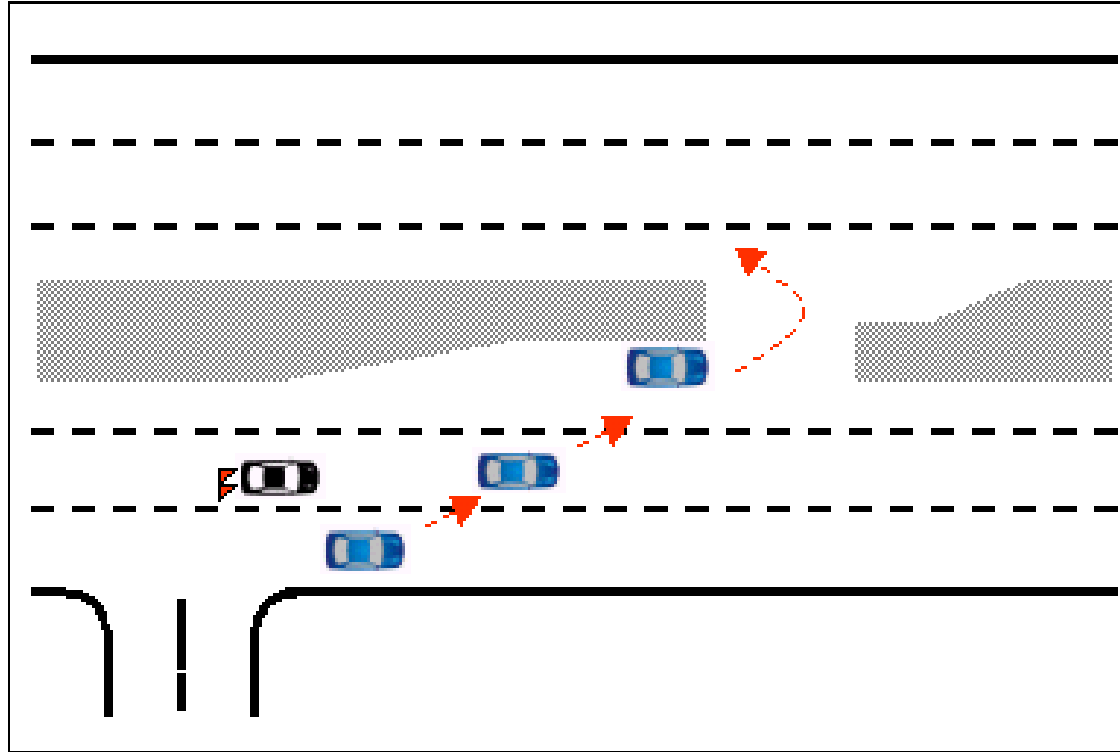

Conflict type C3



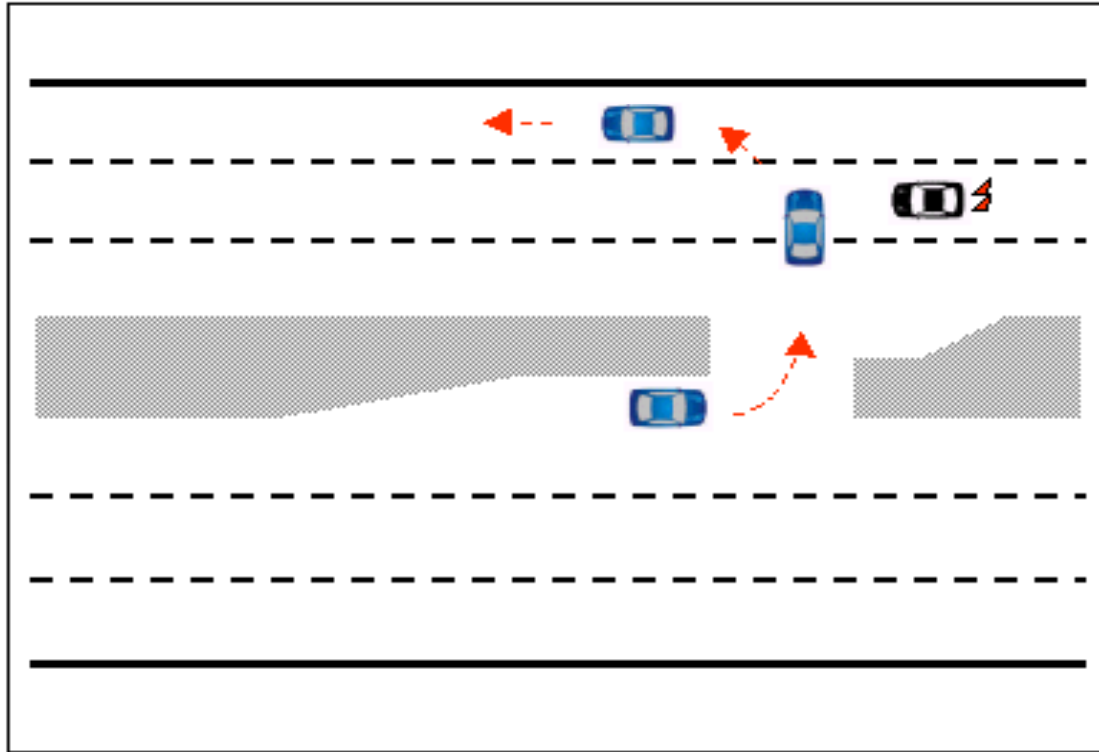

Conflict type C4



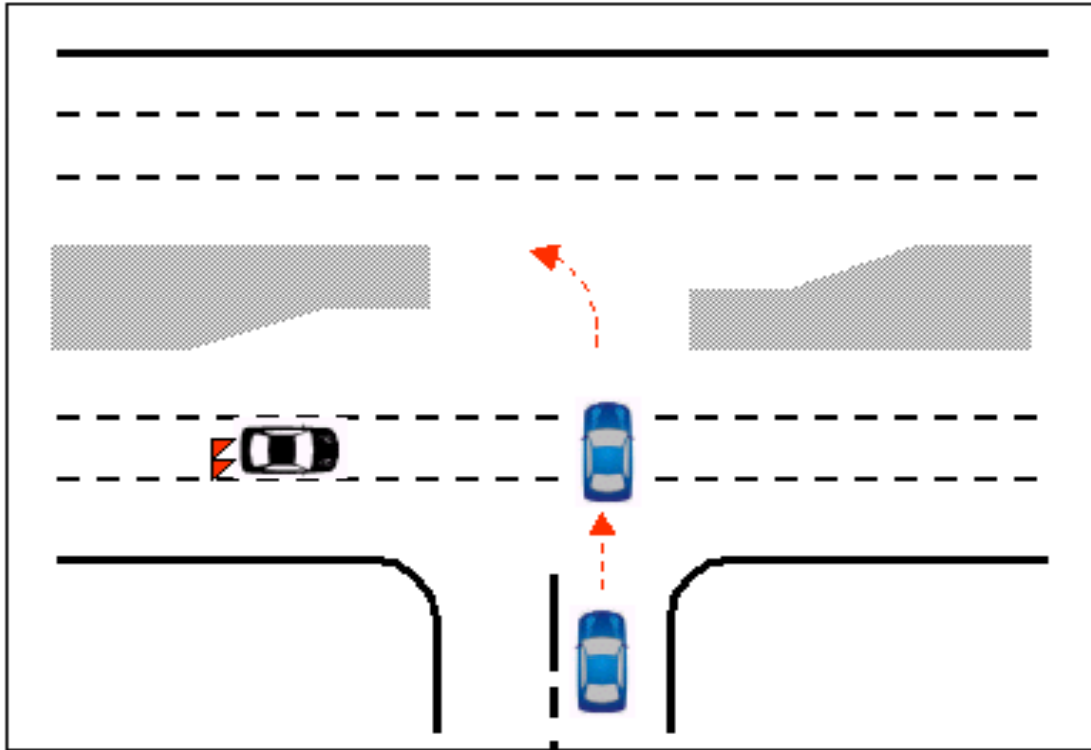

Conflict type C5



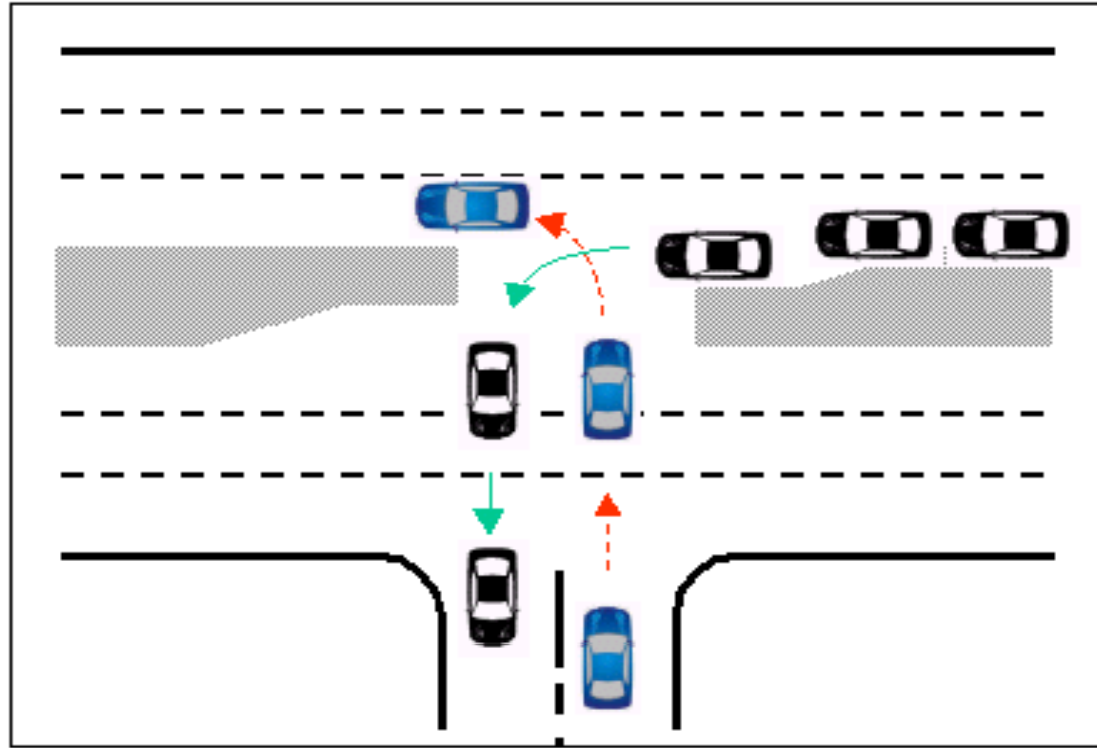

Conflict type C6



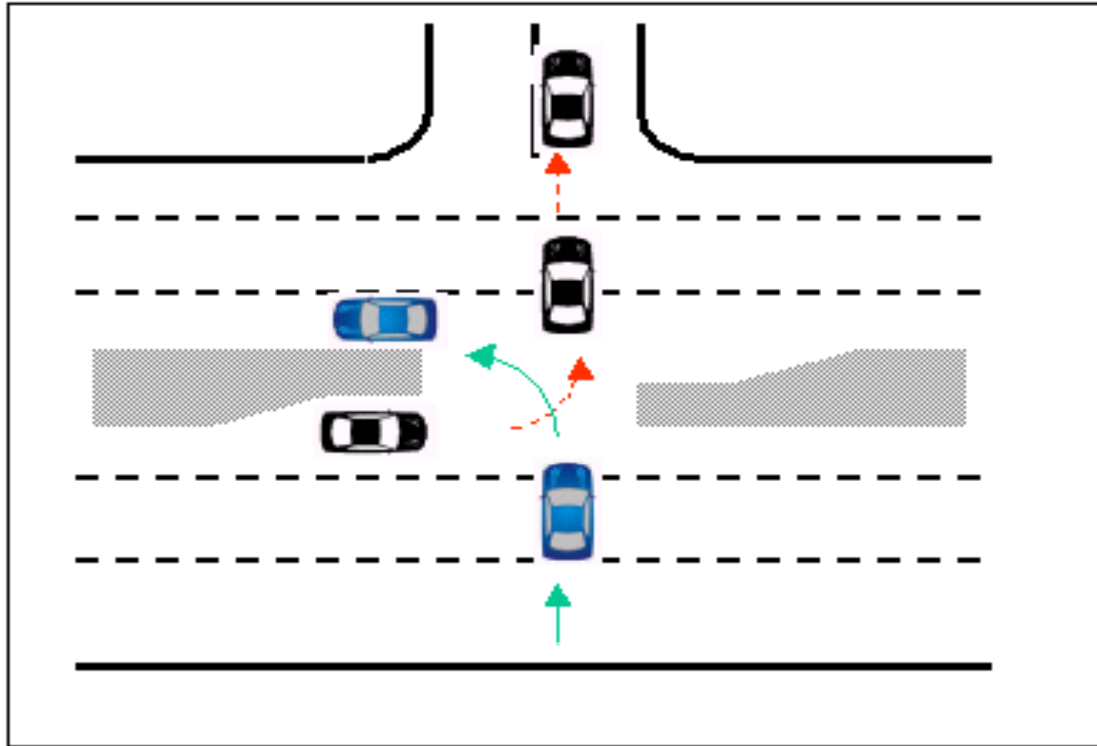

Conflict type C7





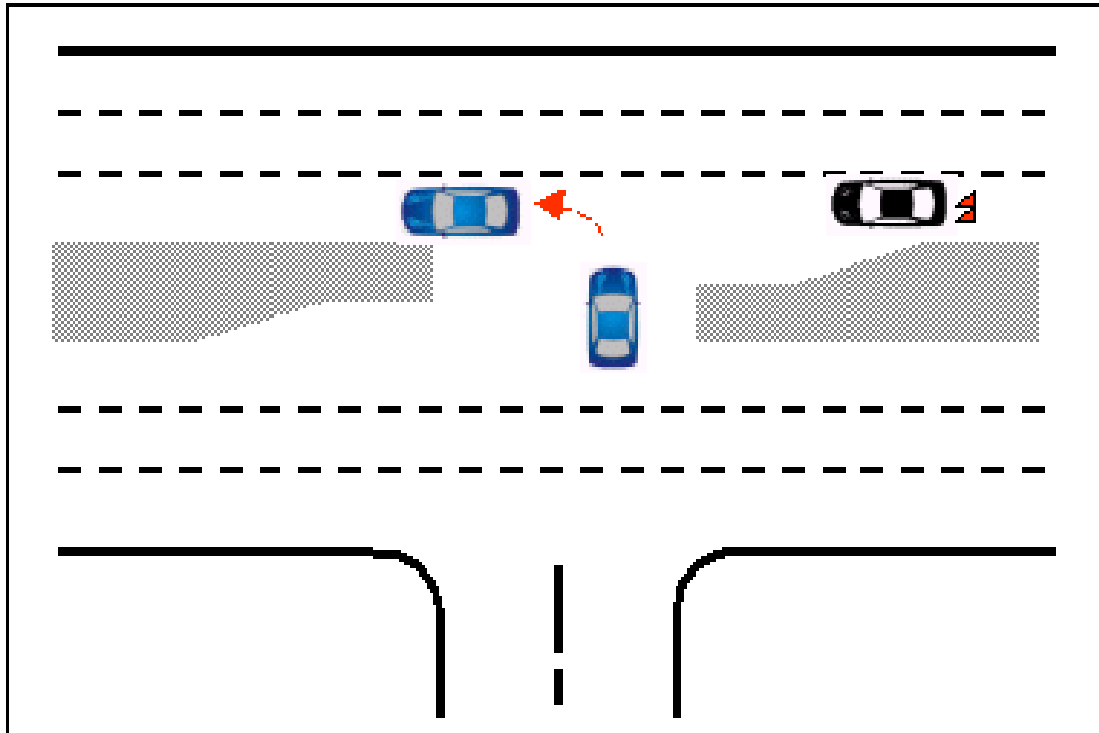

Conflict type C8



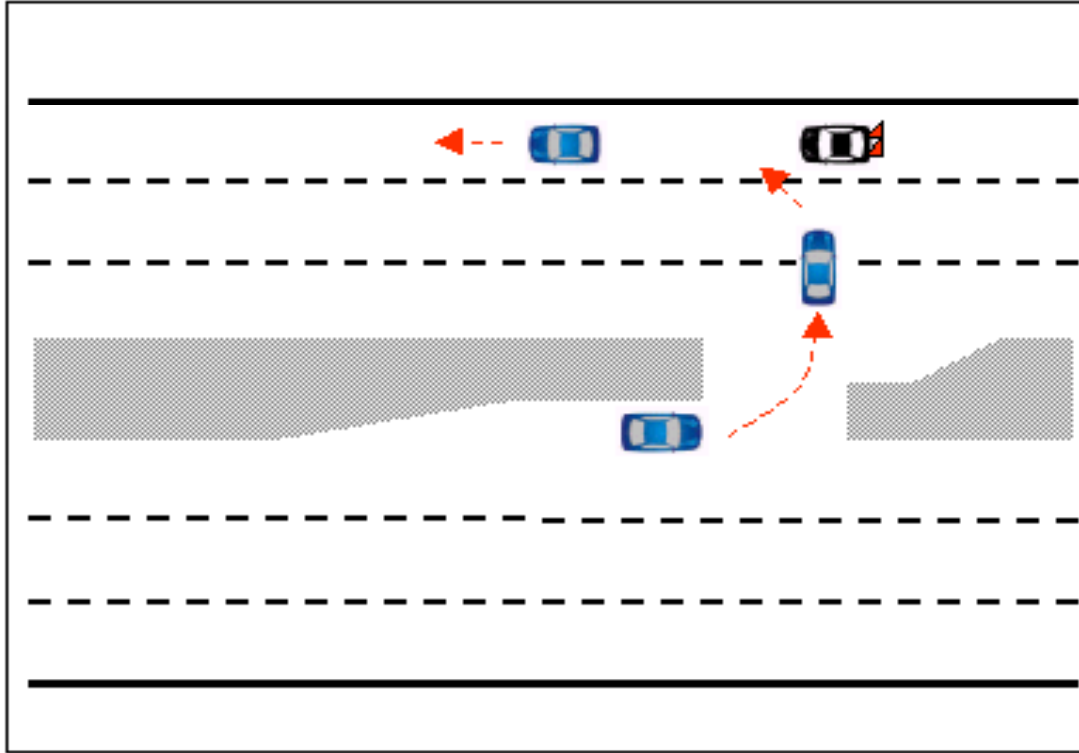

Conflict type C2U-T



# Descriptive analysis

Summary of observations.											
Site	Conflicts	Conflict Type									Total
		C1	C2	C3	C4	C5	C6	C7	C8	C2UT	
1	No.	64	22	23	15	N/A	N/A	N/A	N/A	28	152
	(%)	42.1	14.5	15.1	9.9					18.4	
2	No.	4	9	3	3	75	221	5	36	-	356
	(%)	1.1	2.5	0.8	0.8	21.1	62.1	1.4	10.1		
Before 3	No.	15	17	15	6	150	71	18	74	5	371
	(%)	4	4.6	4	1.6	40.4	19.1	4.9	19.9	1.3	
After 3	No.	40	36	89	118	N/A	N/A	N/A	N/A	44	327
	(%)	12.2	11	27.2	36.1					13.5	
4	No.	1	9	2	2	37	18	-	12	-	81
	(%)	1.2	11.1	2.5	2.5	45.7	22.2		14.8		
5	No.	2	11	2	1	39	22	3	17	-	97
	(%)	2.1	11.3	2.1	1	40.2	22.7	3.1	17.5		
6	No.	1	12	3	9	24	1	2	11	2	65
	(%)	1.5	18.5	4.6	13.8	36.9	1.5	3.1	16.9	3.1	
7	No.	2	15	5	-	41	14	1	21	-	99
	(%)	2	15.2	5.1	-	41.4	14.1	1	21.2		
8	No.	26	22	22	18	N/A	N/A	N/A	N/A	18	106
	(%)	24.5	20.8	20.8	17					17	
TOTAL		155	153	164	172	366	347	29	171	97	1654

# Descriptive analysis

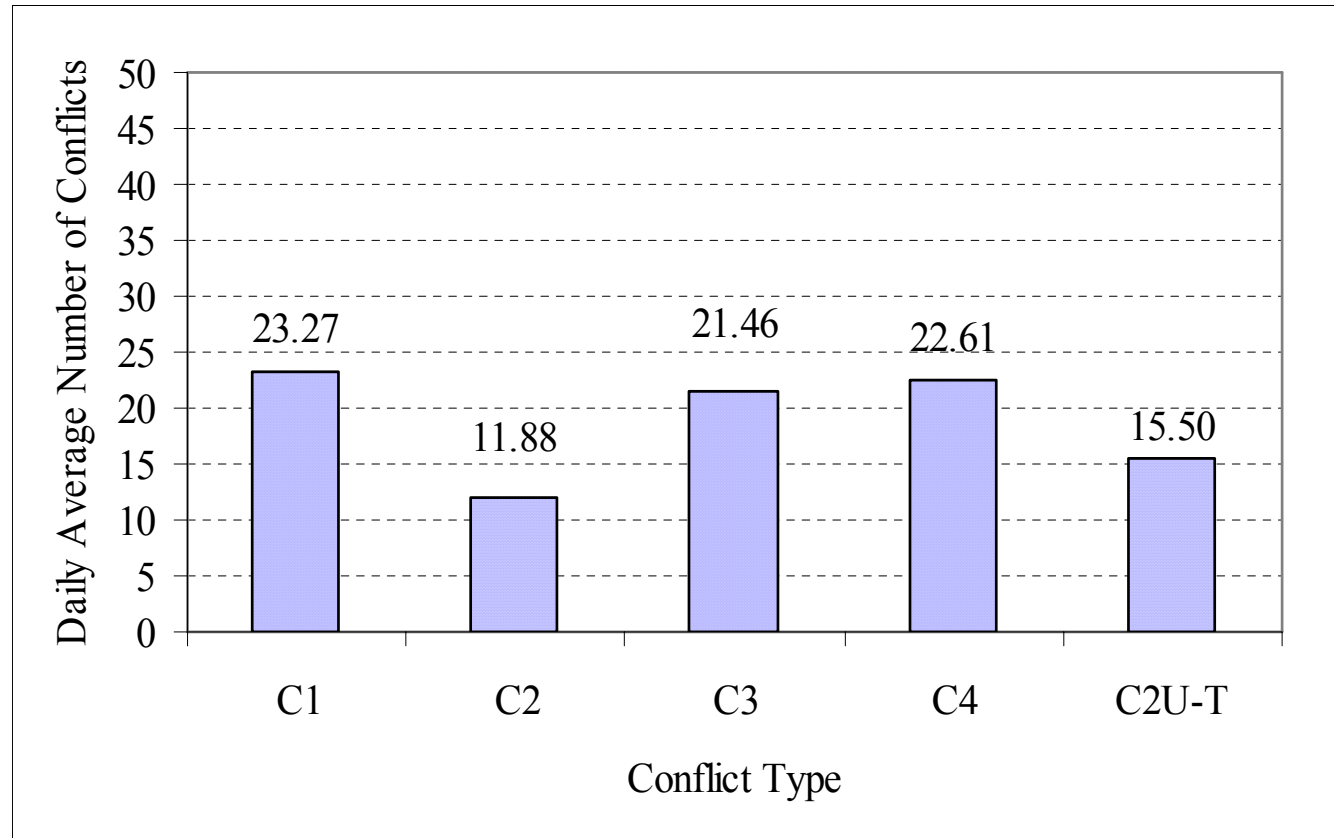

Daily average number of conflicts for RTUT movements by conflict type

# Descriptive analysis

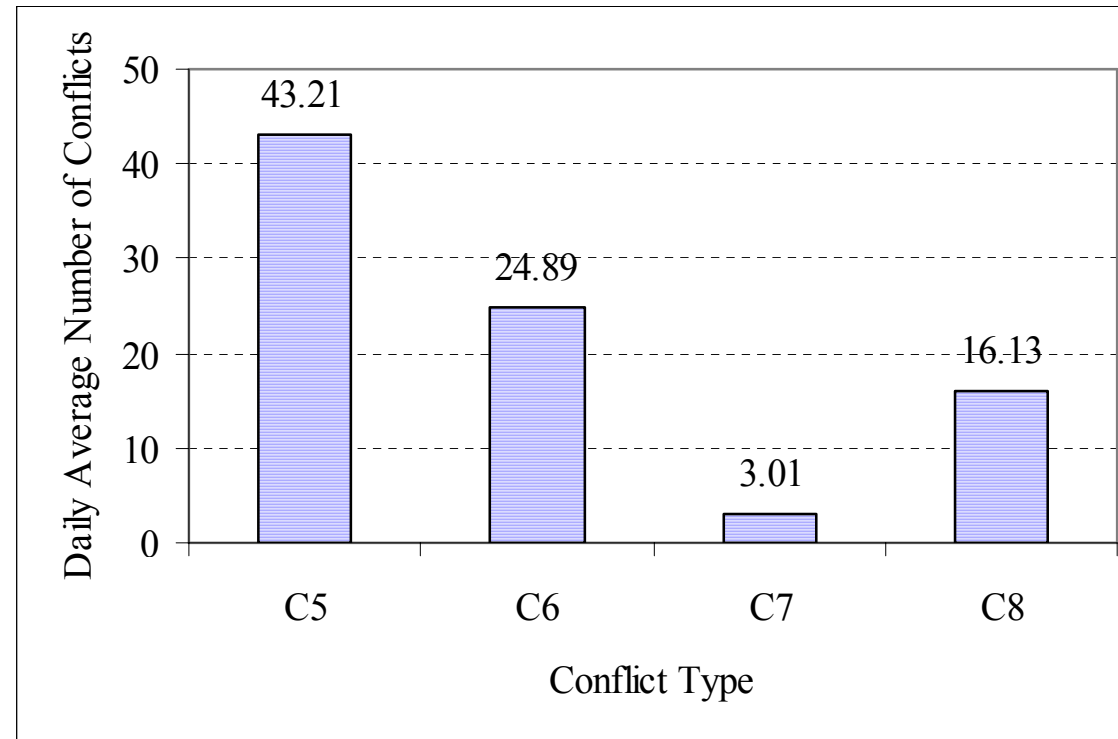

Daily average number of conflicts for DLT movements by conflict type



# Conflict rate analysis

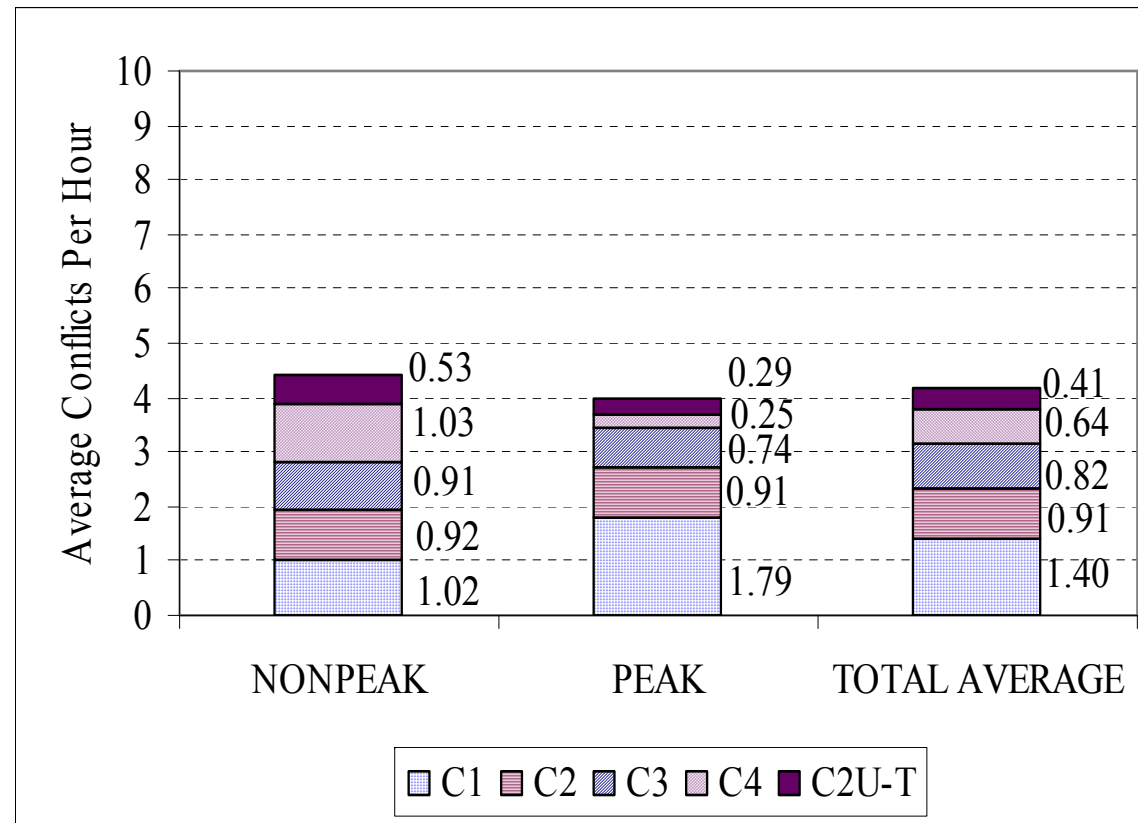

Average number of conflicts per hour of observation for RTUT movements

# Conflict rate analysis

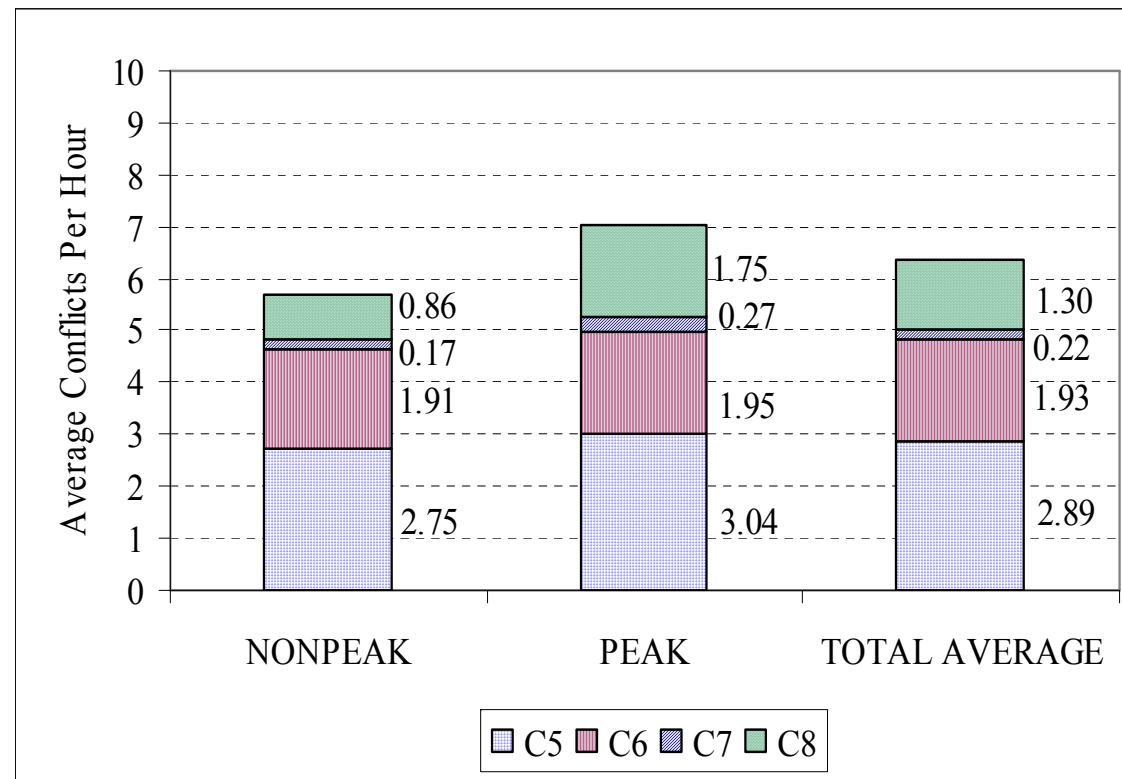

Average number of conflicts per hour of observation for DLT movements

# Conflict rate analysis

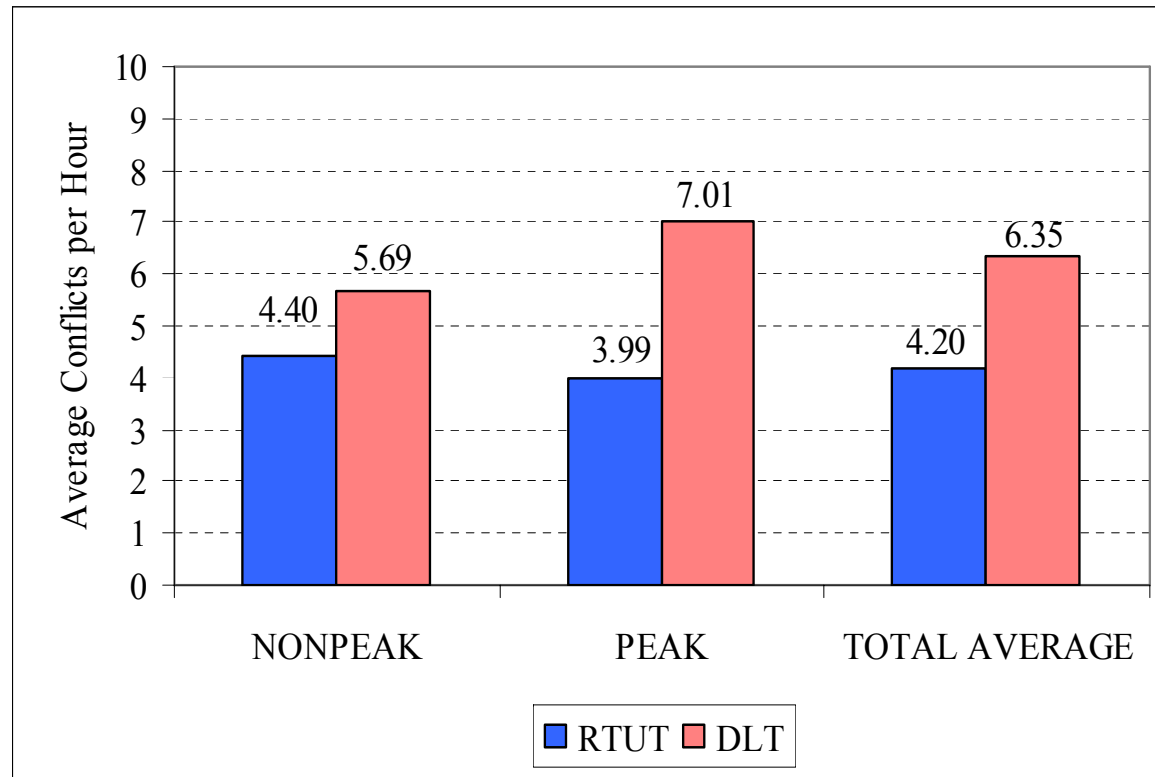

Comparison of average number of conflicts per hour between RTUT and DLT movements, by time period.





# Conflict severity analysis

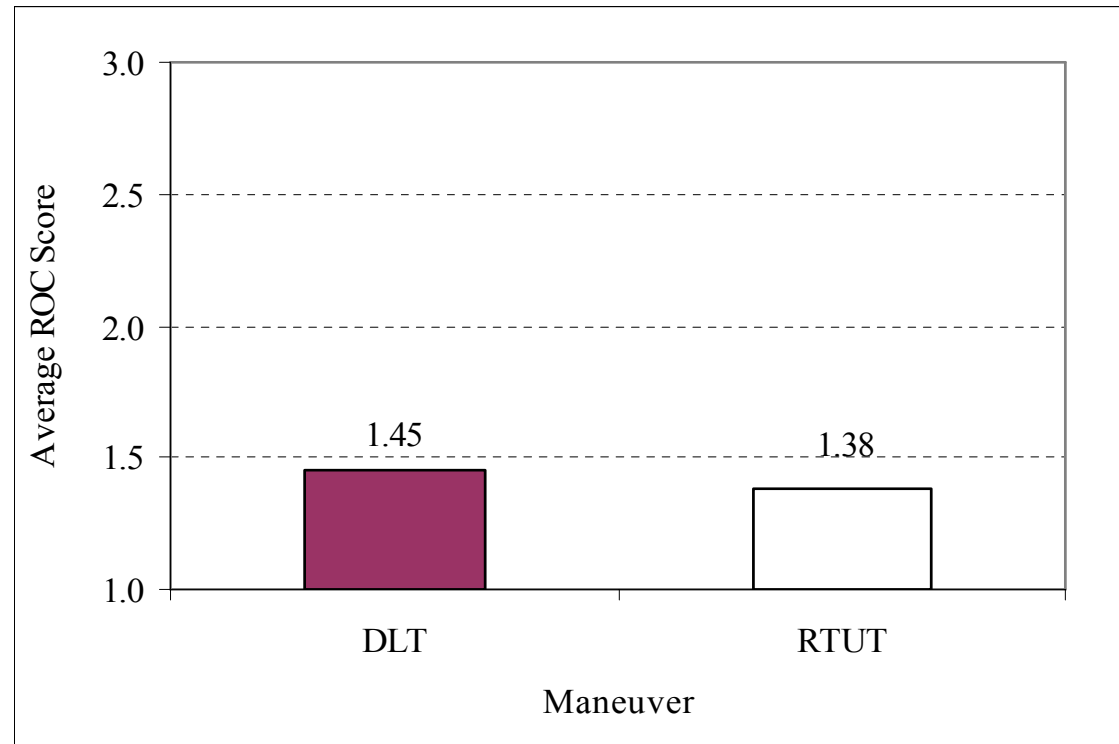

Average severity of conflicts based on ROC Score

# Conflict severity analysis

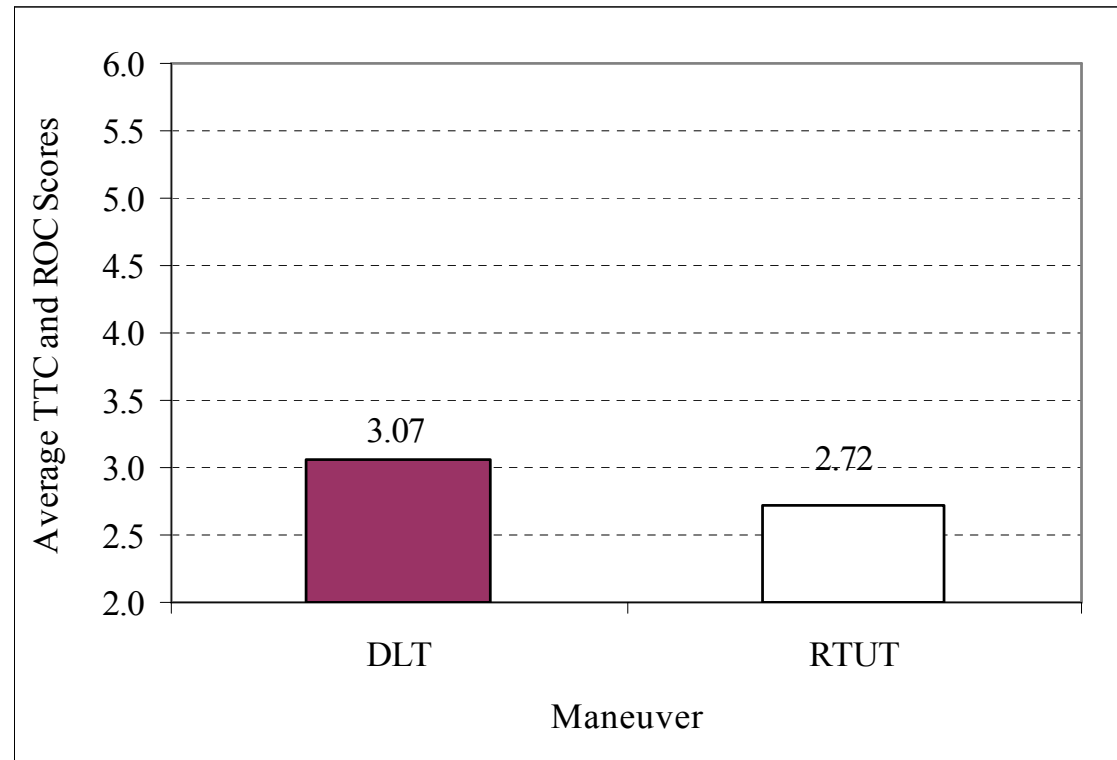

Average severity of conflicts based on ROC and TTC Score

# Conflict severity analysis

SUMMARY						
Groups	Count	Sum	Average	Variance		
RTUT Severity	738	1016	1.376694	0.286675		
DLT Severity	902	1311	1.453437	0.40571		
ANOVA						
Source of Variation	SS	df	MS	F	P-value	F crit
Between Groups	2.390546	1	2.390546	6.788409	0.009258	3.847134
Within Groups	576.8235	1638	0.352151			
Total	579.214	1639				

ANOVA results based on ROC scores

# Conflict severity analysis

SUMMARY						
Groups	Count	Sum	Average	Variance		
RTUT Seve	738	2005	2.716802	0.906122		
DLT Severi	529	1623	3.068053	1.294602		
ANOVA						
Source of V	SS	df	MS	F	P-value	F crit
Between G	38.01631	1	38.01631	35.58679	3.16E-09	3.848811
Within Gro	1351.362	1265	1.06827			
Total	1389.378	1266				

ANOVA results based on ROC and TTC scores



# Before-after analysis

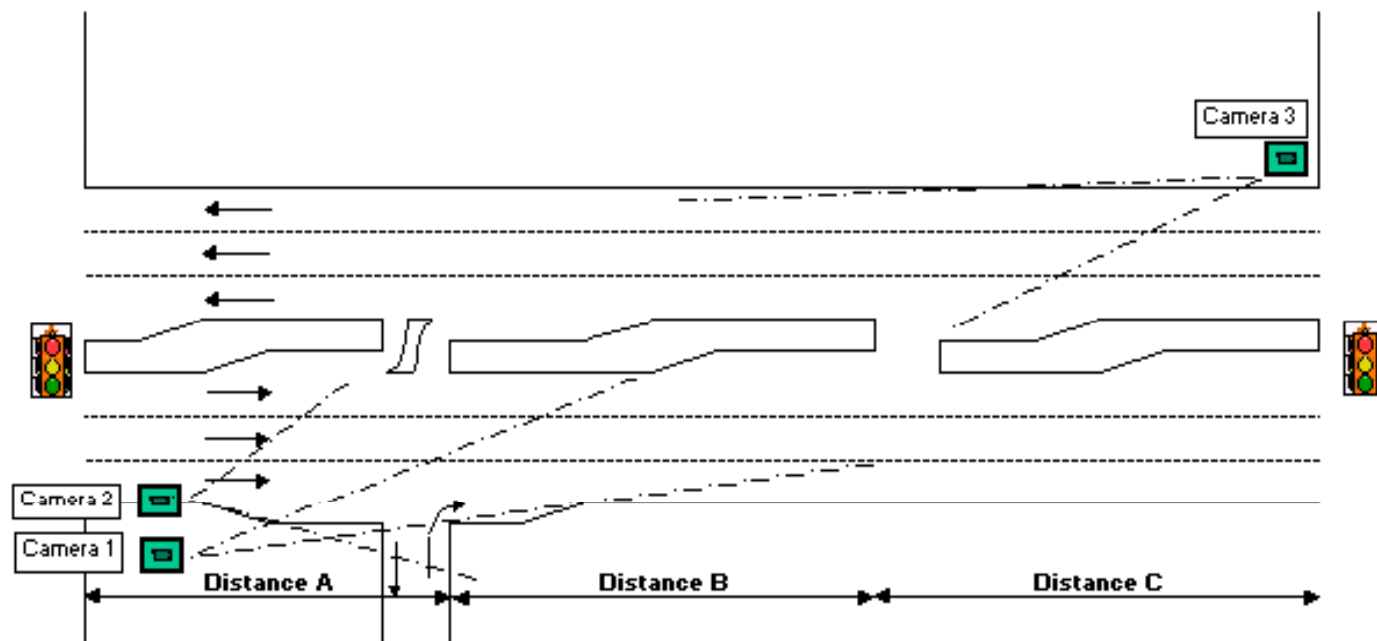

# Before-after analysis

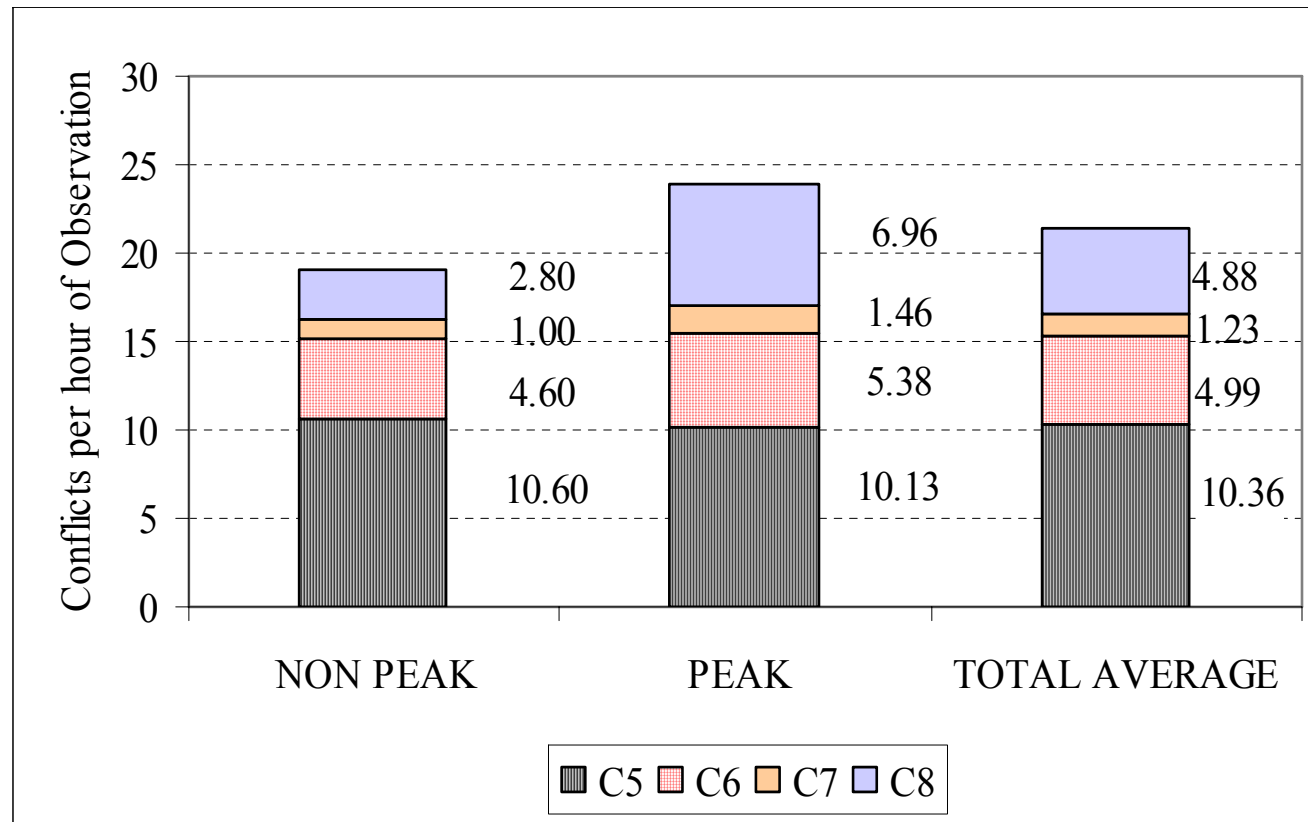

Average number of conflicts per hour of observation for DLT movements "before" improvement

# Before-after analysis

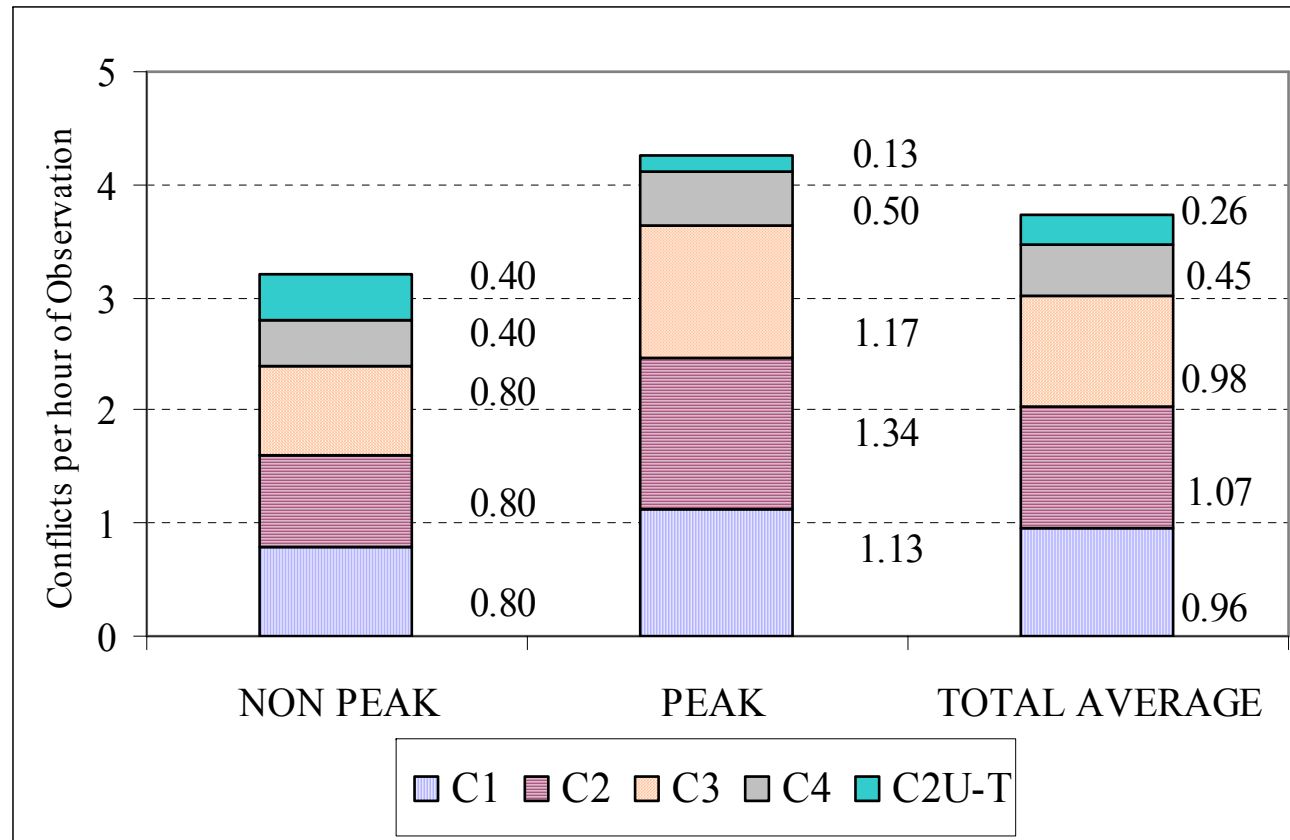

Average number of conflicts per hour of observation for RTUT movements "before" improvement

# Before-after analysis

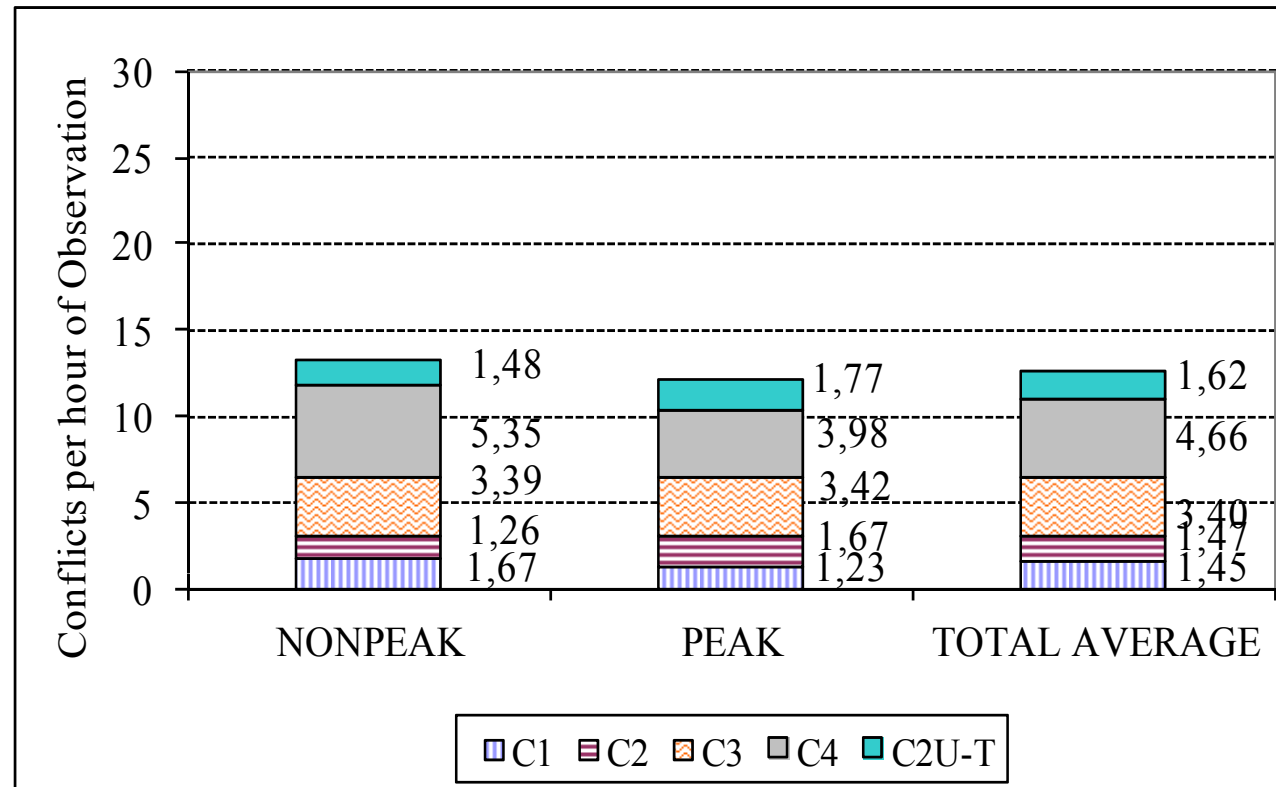

Average number of conflicts per hour of observation for RTUT movements "after" improvement



# Before-after analysis

Average Number of Conflicts per Thousand Involved Vehicles, Method 1.

Time	Before		After RTUT
	DLT	RTUT	
	7:00 - 8:00	103.45	15.26
8:00 - 9:00	71.73	26.21	27.85
9:00 - 10:00	40.80	13.88	37.08
10:00 - 11:00	**35.11	20.2	53.63
11:00 - 12:00	**32.38	18.62	61.96
12:00 - 13:00	51.70	21.94	27.48
13:00 - 14:00	57.05	5.38	32.82
14:00 - 15:00	43.90	11.72	44.86
15:00 - 16:00	37.85	34.37	34.49
16:00 - 17:00	51.35	26.19	46.28
17:00 - 18:00	51.91	13.68	28.04
<b>AVERAGE</b>	<b>52.47</b>	<b>18.86</b>	<b>38.30</b>

\*\* Conflicts estimated according to *Traffic Conflicts Technique: Engineer's Guide*.

